

ILLINOIS STATE POLICE
Office of the Statewide 9-1-1 Administrator



State of Illinois

Application for
9-1-1 Modification Plan

VERIFICATION

I, Steven W. Seiver, first being duly sworn upon oath, depose and say that I am Chairman, of Rock Island County ETSB; that I have read the foregoing plan by me subscribed and know the contents thereof; that said contents are true in substance and in fact, except as to those matters stated upon information and belief, and as to those, I believe same to be true.

Steven W. Seiver

Steven W. Seiver, Chair

Subscribed and sworn to before me

this 22 day of October, 2020.

Arion L. Cox

NOTARY PUBLIC, ILLINOIS



Rock Island County Emergency Telephone System Board

1504 Third Avenue • Rock Island, IL 61201 • 309-793-1900

9-1-1 System Provider Letter of Intent

October 22, 2020

Deb Prather, Director of Regulatory Affairs
INdigital
1616 Director's Row
Fort Wayne, Indiana 46808

Dear Ms. Prather:

This letter is to confirm our intent to modify our 9-1-1 System. Enclosed is your copy of our modification plan to be filed with the Department of the Illinois State Police for approval.

Thank you for your assistance in this matter.

Sincerely,



Steven W. Seiver, Chairman
Rock Island County, Illinois
Emergency Telephone System Board

Enclosure: Modification Plan

NARRATIVE STATEMENT:

(Provide a detailed summary of system operations for a modified 9-1-1 plan. Also, if incorporating an NG9-1-1 solution, please include the additional items listed below pursuant to 1325.205 b)12).

- 1) Indicate the name of the certified 9-1-1 system provider being utilized.
- 2) Explain the national standards, protocols and/or operating measures that will be followed.
- 3) Explain what measures have been taken to create a robust, reliable and diverse/redundant network and whether other 9-1-1 Authorities will be sharing the equipment.
- 4) Explain how the existing 9-1-1 traditional legacy wireline, wireless and VoIP network, along with the databases, will interface and/or be transitioned into the NG9-1-1 system.
- 5) Explain how split exchanges will be handled.
- 6) Explain how the databases will be maintained and how address errors will be corrected and updated on a continuing basis.
- 7) Explain who will be responsible for updating and maintaining the data, at a minimum on a daily basis Monday through Friday.
- 8) Explain what security measures will be placed on the IP 9-1-1 network and equipment to safeguard it from malicious attacks or threats to the system operation and what level of confidentiality will be placed on the system in order to keep unauthorized individuals from accessing it.

Plan Narrative:

The Rock Island County Emergency Telephone System Board is requesting to change its 9-1-1 System Service Provider (9-1-1 SSP) from AT&T to INdigital Telecom. The system will be provisioned as an IP based NG911 System.

The Rock Island County NG911 System will comply with all State and Federal requirements and be compliant with the National Emergency Number Association standards.

The network will be provisioned as an IP based, Next Generation network and will deliver calls using IP technology to the Rock Island County PSAPs. Access is password protected. The Enhanced 9-1-1 network is private with no outside access. There will be redundant Legacy Network Gateways (LNGs) and Internet Protocol Selective Routers (IPSRs). One set is located in Mattoon, Illinois and the other is located in Rosiclare, Illinois. Carriers can deliver 9-1-1 calls to the IPSRs or LNGs by using SS7 signaling or by using SIP trunk, IP based signaling. Please see the attached network diagram.

Router to router trunks will be established between INdigital's IPSRs and selective routers owned by other 9-1-1 SSPs for routing of split exchanges where necessary.

INdigital will administer the 9-1-1 database and MSAG for Rock Island County subscribers. INdigital will request TN loads and updates from the carriers prior to the cutover and assume all 9-1-1 SSP administrative responsibilities for the database at the time of conversion. INdigital will work with the carriers and Rock Island County to keep the database up to date and in compliance with the Illinois State law, on an ongoing basis.

INdigital will coordinate the ordering and installation of trunks to the two new LNGs or IPSRs. INdigital will work with the carriers that are currently connected to the AT&T selective router for delivery of wireline and wireless 9-1-1 calls to Rock Island County. Traffic will be migrated over, carrier by carrier, to the new LNGs or IPSRs. The target completion date for migration is January 13, 2021.

INdigital will mirror current call transfer conditions at the time of conversion and will implement 9-1-1 call transfer with ANI between neighboring jurisdictions of Rock Island County, where possible, post conversion.

FINANCIAL INFORMATION

Annual recurring 9-1-1 network costs prior to modification	\$ <u>153,000.00</u>
Projected annual recurring 9-1-1 network costs after modification	\$ <u>208,339.00</u>
Installation cost of the project	\$ <u>467,797.00</u>
Anticipated annual revenues	\$ <u>2,040,000.00</u>

FIVE YEAR STRATEGIC PLAN FOR MODIFIED PLAN

(Provide a detailed summary of the proposed system's operation, including but not limited to, a five-year strategic plan for implementation of the modified 9-1-1 plan with financial projections)

Narrative:

The Rock Island County Emergency Telephone System Board has a thirty year history of providing E9-1-1 services to the residents and businesses of Rock Island County. During these three decades many upgrades and enhancements have occurred, including the recently mandated consolidation of PSAP facilities and extensive improvements on call handling and physical back-up capabilities.

During 2020, the ETSB has also provisioned four portable laptop answering stations for contingencies that would require physically locating dispatchers from one or more PSAPs. This was instituted as an additional safeguard in the event of natural or man-made interruptions to normal 9-1-1 call delivery.

Looking forward, the foundation of the five-year plan is the implementation of the NG911 call delivery system as outlined in the application's Plan Narrative. With NG911, the county will have increased reliability and a fully diverse network solution.

The ETSB will continue to look for efficiencies in operations while maintaining cost effective call taking and dispatch services to the citizens, businesses and first responders of Rock Island County. The five year plan also includes the following upgrades/enhancements:

- 1) Continue with the maintenance and life-cycle replacement of 9-1-1 networking and PSAP equipment (2021-2025);
- 2) Upgrade call recording equipment (2020-2021);
- 3) Refresh CAD software and hardware (2021-2022);
- 4) Expand support of video for situational awareness in the PSAP and to emergency service providers in the field (2021-2025);
- 5) Improve Text-to-911 services (2021); and
- 6) Upgrade PSAP radio and console equipment to support a new P25 public safety trunked radio system in Rock Island County, IL and Scott County, IA (2020-2021).

PARTICIPATING AGENCIES

Provide a list of public safety agencies (Police, Fire, EMS etc.) that are to be dispatched by the 9-1-1 System. Each Agencies land area(s) in square miles and estimated population which will have access to the proposed 9-1-1 System. Do not forget to include County Sheriff's jurisdiction and Illinois State Police Districts. Each agency that appears on this list should also have signed a call handling agreement.

9-1-1 Participant Agencies	Street Address, City, Zip Code	Administrative Telephone No.	Direct Dispatch	Transfer	Call Relay
ISP, District 7	800 Hillcrest Road, East Moline, 61244	(309) 752-4915		X	
Rock Island Co Sheriff's Office	1317 Third Avenue, Rock Island, 61201	(309) 794-1230	X		
Coal Valley Police	900 1st Street, Coal Valley, IL 61240	(309) 799-5416	X		
East Moline Police	915 16th Avenue, East Moline, IL 61244	(309) 752-1555	X		
Hampton Police	901 4th Street, Hampton, IL 61256	(309) 737-3144	X		
Hillsdale Police	402 Main Street, Hillsdale, IL 61257	(309) 658-2501	X		
Milan Police	405 1st Street E, Milan, IL 61264	(309) 787-8520	X		
Moline Police	1640 6th Avenue, Moline, IL 61265	(309) 797-0401	X		
Rock Island Police	1212 5th Avenue, Rock Island, IL 61201	(309) 732-2677	X		
Silvis Police	600 Illini Drive, Silvis, IL 61282	(309) 792-1841	X		
Andalusia Ambulance	220 6th Avenue W, Andalusia, IL 61232	(309) 798-5406	X		
Andalusia/Edgington Fire	212 1st Street, Andalusia, IL 61232	(309) 798-2030	X		
Blackhawk Volunteer Fire	102 3rd Street W, Milan, IL 61264	(309) 787-1131	X		
Buffalo Prairie/IL City Fire	24019 124th Ave W, Illinois City, IL 61259	(563) 506-8939	X		
Carbon Cliff/Barstow Fire	305 N 2nd Avenue, East Moline, IL 61244	(309) 792-5449	X		
Coal Valley Fire/First Respond	103 W 18th Avenue, Coal Valley, IL 61240	(309) 799-5534	X		
Cordova Fire	906 Main Avenue, Cordova, IL 61242	(309) 654-2371	X		
East Moline Fire	1523 Morton Drive, East Moline, IL 61244	(309) 523-2511	X		
Hampton Fire	601 3rd Avenue, Hampton, IL 61256	(309) 755-6182	X		
Hillsdale Fire	412 Main, Hillsdale, IL 61257	(309) 658-2515	X		
Moline Fire/Ambulance	1630 8th Avenue, Moline, IL 61265	(309) 524-2250	X		
Orion Fire	501 11th Avenue, Orion, IL 61273	(309) 526-3365	X		
Port Byron/Rapids City Fire	120 S Main Street, Port Byron, IL 61275	(309) 523-2511	X		
Reynolds Fire	203 N Main Street, Reynolds, IL 61279	(309) 372-4212	X		
Sherrard Fire	101 E 1st Street, Sherrard, IL 61281	(309) 593-2412	X		

TEST PLAN DESCRIPTION

1) Description of test plan (back-up, overflow, failure, database).

All Carriers will make test calls the day of the cutover to the PSAPs to confirm that all of their subscribers are able to complete calls to the proper PSAP with correct ANI/ALI information.

The wireline carriers will make test calls from each exchange to make sure calls are routing to the correct PSAP with the correct ANI/ALI information. The wireless and VoIP provider will also make test calls and complete correctly as Phase II with ANI/ALI and Lat/Long. All carriers have a back out plan if they run into problems.

Test calls will be made to confirm overflow, backup, and failover work effectively and properly.

2) List wireline exchanges to be tested.

AT&T: East Moline, Edgington, Illinois City, Moline & Rock Island

Frontier: Albany, Cordova, Eliza, Hampton, Hillsdale, Orion Main, Orion North, Port Byron, Preemption, Sherrard

Reynolds: Reynolds

3) List of wireless and VoIP Carriers to be tested.

AT&T Mobility, Verizon Wireless, US Cellular, T-Mobile/Sprint

Mediacom, CenturyLink, Geneseo Communications, Verizon Business, Teleport Communications, CS Technologies, New Windsor Cable

AN ORDINANCE CREATING
THE EMERGENCY TELEPHONE
SYSTEM BOARD OF
ROCK ISLAND COUNTY, ILLINOIS

WHEREAS, the provisions of Chapter 134, §45.4, Illinois Revised Statutes, as amended by P.A. 85-978, require that the corporate authorities of any County which imposes a surcharge under the provisions of Chapter 134, §45.3, Illinois Revised Statutes, to establish an Emergency Telephone System Board, and

WHEREAS, the County of Rock Island has imposed such a surcharge,

BE IT ORDAINED BY THE COUNTY BOARD OF ROCK ISLAND COUNTY, ILLINOIS, IN OPEN MEETING THIS 16 DAY OF FEBRUARY, A.D. 1988, as follows:

Section 1. That the Emergency Telephone System Board of Rock Island County, Illinois, be and hereby is established.

Section 2. That the Emergency Telephone System Board of Rock Island County, Illinois, shall consist of nine (9) members, appointed on the basis of their experience and ability. The members of the Emergency Telephone Systems Board of Rock Island County, Illinois, shall serve without compensation, but shall be reimbursed for actual and necessary expenses.

Section 3. That six (6) members of the Emergency Telephone System Board of Rock Island County, Illinois, shall be representatives of the governmental entities which will be Public Safety Answering Points in any 911 system implemented in Rock Island County, Illinois, such governmental entities being:

1. The County of Rock Island, Illinois
2. The City of Rock Island, Illinois
3. The City of Moline, Illinois
4. The City of East Moline, Illinois
5. The City of Silvis, Illinois
6. The Village of Milan, Illinois

A member representing a municipality shall be appointed by the Chairman of the County Board upon the recommendation of the Mayor or President of the Board of Trustees of the municipality, with the advise and consent of the County Board. The County representative shall be appointed by the Chairman of the County Board with the advise and consent of the County Board.

Section 4. That two (2) members of the Emergency Telephone System Board of Rock Island County, Illinois, shall be appointed based upon their residence in areas of Rock Island County which provide emergency services but which are not set forth in Section Three (3) of this Ordinance, to wit: Upper Rock Island County and Lower Rock Island County; and one (1) member of the Emergency Telephone System Board of Rock Island County, Illinois, shall have no residence qualifications other than being a resident of Rock Island County, Illinois. These appointments shall be made by the chairman of the County Board, with the advise and consent of the County Board.

Section 5. The powers and duties of the Emergency Telephone System Board of Rock Island County, Illinois, shall be as follows:

1. Planning a 911 system for Rock Island County, Illinois.
2. Co-ordinating and supervising the implementation, upgrading, or maintenance of the system, including the establishment of equipment specifications and coding systems.
3. Receiving monies from the surcharge imposed under Chapter 134, §45.3, Illinois Revised Statutes, and from any other source, for deposit into the Emergency Telephone System Fund.
4. Authorizing all disbursements from such fund, by means of resolutions adopted by a majority of all the members of the Emergency Telephone Service Board, for purposes authorized by law.
5. Hiring, on a temporary basis, any staff necessary for the implementation or upgrade of the system, and providing for the compensation of such staff.
6. To adopt rules providing for its procedures, organization, and officers. Provided: that the County Treasurer of Rock Island County shall be the treasurer of the Emergency Services Board.
7. To do all things related to the purposes for which it was created not prohibited by law.

Section 6. The term of office of all persons appointed to the Emergency Telephone System Board of Rock Island County, Illinois, shall be two years. The term of office of original appointees shall commence on April 1, 1988, and end at midnight, March 31, 1990. Successor appointees shall be appointed for terms of similar duration. There shall be no limit in the number of terms a member may serve.

Section 7. A vacancy on the Emergency Telephone System Board of Rock Island County, Illinois may be occasioned by the resignation, death, removal from an appropriate geographical area, physical or mental incapacity, or continual refusal to attend scheduled meetings of or by a member. The appointing authority shall have the power to determine the existence of a vacancy. All vacancies shall be filled within sixty (60) days from the date the appointing authority determines a vacancy to exist.

Section 8. There shall be an annual meeting of the Emergency Telephone System Board in the month of April of each calendar year. The original Emergency Telephone System Board, and such successor Emergency Telephone System Board, shall conduct its organizational activities at such meeting. Other regular and special meetings shall be held and convened as the Emergency Telephone System Board may provide in its rules. The Chairman of the County Board of Rock Island County has the authority to call the Emergency Telephone System Board into services by giving such member thereof telephone notice at least 24 hours in advance of the time the meeting is to begin. The regular meeting place of the Emergency Telephone System Board shall be the County Office Building, 1504 3rd Avenue, Rock Island, Illinois, but the Emergency Telephone System Board may schedule meetings at other accessible locations in Rock Island County, Illinois.

Section 9. Whenever a power of appointment to the Emergency Telephone System Board is exercised, the appointing authority shall immediately notify the Chairman of the County Board of Rock Island County, who shall in turn notify the Emergency Telephone System Board.

Section 10. This ordinance shall become effective immediately upon its adoption, and appointments to the Emergency Telephone System Board may be made at any time hereafter by appropriate appointing authorities.

DONE IN OPEN MEETING THIS 16 DAY OF FEBRUARY, A.D. 1988.

THE COUNTY BOARD OF ROCK ISLAND
COUNTY ILLINOIS.

by 
PAUL E. MULCAHEY, Chairman

ATTEST:

RICHARD LEIBOVITZ, County Clerk

**9-1-1 SERVICES AND
SOFTWARE LICENSE AGREEMENT**

This 9-1-1 Services and Software License Agreement (this “**Agreement**”), together with any other documents incorporated into this Agreement by reference (including all Exhibits to this Agreement, including the General Terms and Conditions of Software License, which are attached to this Agreement as Exhibit A), constitute the sole and entire agreement of the Parties with respect to the subject matter of this Agreement and supersede all prior and contemporaneous understandings, agreements, representations and warranties, both written and oral, with respect to such subject matter. The State of Illinois regulates the provision of 9-1-1 services at 50 ILCS 750/.01 *et seq*, 220 ILCS 5/13-900, and further at IL. Ad. Code Title 83, Chapter IV, Part 1325. This agreement shall be construed and interpreted in accordance with the above stated laws and regulations together with any other applicable laws which are from time to time enacted and, or, adopted. In the event that a conflict between the terms of this agreement and relevant law arises, relevant law shall prevail.

The exhibits, attachments and appendices referred to in this Agreement are incorporated into this Agreement by reference and are an integral part of this Agreement to the same extent as if they were set forth verbatim in this Agreement, and the Parties have read, understand, and agree to all terms and conditions of all such exhibits, attachments, and appendices.

Any capitalized terms used, but not defined, below will have the meanings ascribed to them in the General Terms and Conditions of Software License attached to this Agreement as Exhibit A and incorporated into this Agreement by reference in their entirety.

1. Purpose

Grant of a *non-exclusive, non-sub licensable and non-transferable*, limited license to use the Software, which shall include any third-party software, necessary or required for the operation of Customer’s emergency telephone system in the Territory.

Type of Agreement/Document

- Original Agreement
- Amendment

2. Parties/Notices:

INdigital:

Communications Venture Corporation (d/b/a INdigital Telecom) (“**INdigital**”)

1616 Directors Row
Fort Wayne, IN 46808
Fax: (260) 469-4329
E-mail: contracts@indigital.net
Attention: Contract Administration

Customer:

Rock Island County, IL ETSB (“**Customer**” and together with INdigital, the “**Parties**”, and, each, individually, a “**Party**”)

Address: 405 East First Street
Milan, IL 61264

Phone: 309-787-8507
E-mail: steveseiver@milan.il.us
Contact Person: Steve Seiver

3. Effective Date

08/17/2019 2019 (“**Effective Date**”).

4. Software

Software listed and described in Exhibit C attached to, and incorporated by reference into, this Agreement, together with any Maintenance Releases provided to Customer pursuant to this Agreement.

5. Territory

Rock Island Co. IL (“**Territory**”).

6. Permitted Use

Use of the Software by Customer for the purpose of operating an emergency telephone system in the Territory (“**Permitted Use**”).

7. Installation

INDigital will deliver and install one copy of the Software to Customer.

8. Maintenance Releases

During the Term, INDigital will provide Customer with all Maintenance Releases that INDigital may make generally available to its licensees at no additional charge.

9. License Fee

See Exhibit D attached to, and incorporated by reference into, this Agreement. If the Term is renewed, Customer will pay the then-current standard license fees that INDigital charges for the Software.

10. Additional Charges

See Exhibit D attached to, and incorporated by reference into, this Agreement for an exhibit of additional charges, if any, for installation, training, and acceptance testing services.

11. Term

Initial Term: From Effective Date until **five (5)-year** anniversary of such date unless terminated earlier pursuant to any of the Agreement’s express provisions.

Renewal Terms: This Agreement will automatically renew for additional successive 12-month terms unless earlier terminated pursuant to any of the Agreement’s express provisions or either Party gives the other Party written notice of non-renewal at least ninety (90) days prior to the expiration of the then-current term.

12. Exhibits

- Exhibit A** – General Terms and Conditions of Software License (attached to, made part of, and incorporated in its entirety by reference into, this Agreement).
- Exhibit B** – Designated Sites
- Exhibit C** - Software/Services Description
- Exhibit D** – Payment and Fees

13. Other Agreements between Parties

- Equipment Purchase and Sale Agreement
- Support and Maintenance Agreement

This Agreement may be executed in counterparts, each of which is deemed an original, but all of which together are deemed to be one and the same agreement. A signed copy of this Agreement delivered by facsimile, e-mail or other means of electronic transmission is deemed to have the same legal effect as delivery of an original signed copy of this Agreement.

CUSTOMER:

INDIGITAL:

Rock Island Co. IL ETSB

COMMUNICATION VENTURE CORPORATION (D/B/A INDIGITAL)

DocuSigned by:
Steve Seiver

9CFD0DC047EC486...

Name: Steve Seiver
Title: Rock Island Co. ETSB Chairman

DocuSigned by:
John Whirlledge

4727AA270E43402...

Name: John Whirlledge
Title: V.P. Business Development

EXHIBIT A
GENERAL TERMS AND CONDITIONS
(9-1-1 SERVICES AND SOFTWARE LICENSE)

These General Terms and Conditions for INdigital's 9-1-1 Services and Software License Agreement (the "**Terms**") supplement the related specific 9-1-1 Services and Software License Agreement (together with these Terms, the "**Agreement**") between you ("**you**" or "**Customer**") and Communications Venture Corporation (d/b/a INdigital), an Indiana corporation ("**INdigital**"), for the grant by INdigital to you of a license to certain software specified in the Agreement. These Terms will be deemed to be a part of and are hereby incorporated by reference into the Agreement.

These Terms prevail over any of Customer's general terms and conditions regardless of whether or when Customer has submitted its request for proposal, order, or such terms. Provision of services, software license, equipment or other products or goods to Customer does not constitute acceptance of any of Customer's terms and conditions and does not serve to modify or amend these Terms.

INdigital and you may each individually be referred to as a "**Party**" and collectively as the "**Parties**".

1. **DEFINITIONS.** Capitalized terms used in the Agreement (including these Terms) have the meanings set forth or referred to in this Section 1:

- | | |
|--|--|
| <p>1.1. "Acceptance Testing" has the meaning set forth in <u>Section 4</u> of these Terms.</p> <p>1.2. "Action" has the meaning set forth in <u>Section 8.2(d)</u> of these Terms.</p> <p>1.3. "Affiliate" of a Person means any other Person that directly or indirectly, through one or more intermediaries, controls, is controlled by, or is under common control with, such Person. The term "control" (including these Terms "controlled by" and "under common control with") means the direct or indirect power to direct or cause the direction of the management and policies of a Person, whether through the ownership of voting securities, by contract or otherwise.</p> <p>1.4. "Business Day" means a day other than a Saturday, Sunday or other day on which commercial banks in Fort Wayne, Indiana are authorized or required by Law to be closed for business.</p> <p>1.5. "Confidential Information" has the meaning set forth in <u>Section 5.1</u> of these Terms.</p> <p>1.6. "Controlled Technology" means any software, documentation, technology or other technical data, or any products that</p> | <p>include or use any of the foregoing, the export, re-export or release of which to certain jurisdictions or countries is prohibited or requires an export license or other governmental approval, under any Law, including the US Export Administration Act and its associated regulations.</p> <p>1.7. "Customer" has the meaning set forth in the preamble to these Terms.</p> <p>1.8. "Designated Sites" means any of Customer's facilities set forth in <u>Exhibit B</u> attached to, and incorporated by reference into, the Agreement.</p> <p>1.9. "Disclosing Party" has the meaning set forth in <u>Section 5.1</u> of these Terms.</p> <p>1.10. "Documentation" means any and all manuals, instructions and other documents and materials that INdigital and/or any third-party provides or makes available to Customer in any form or medium which describe the functionality, components, features or requirements of the Software, including any aspect of the installation, configuration, integration, operation, use, support or maintenance thereof.</p> <p>1.11. "Effective Date" has the meaning set forth in <u>Section 3</u> of the Agreement.</p> <p>1.12. "Force Majeure Event" has the meaning set forth in <u>Section 14.1</u> of these Terms.</p> <p>1.13. "Indemnitee" has the meaning set forth in <u>Section 11.3</u> of these Terms.</p> <p>1.14. "Indemnitor" has the meaning set forth in <u>Section 11.3</u> of these Terms.</p> <p>1.15. "INdigital" has the meaning set forth in the preamble to these Terms.</p> <p>1.16. "INdigital Indemnitee" has the meaning set forth in <u>Section 11.2</u> of these Terms.</p> <p>1.17. "Initial Term" has the meaning set forth in <u>Section 9.1</u> of these Terms.</p> <p>1.18. "Intellectual Property Rights" means any and all registered and unregistered rights granted, applied for or otherwise now or hereafter in existence under or related to any patent, copyright, trademark, trade secret, database</p> |
|--|--|

EXHIBIT A
GENERAL TERMS AND CONDITIONS
(9-1-1 SERVICES AND SOFTWARE LICENSE)

- protection or other intellectual property rights laws, and all similar or equivalent rights or forms of protection, in any part of the world.
- 1.19. “**Law**” means any statute, law, ordinance, regulation, rule, code, order, constitution, treaty, common law, judgment, decree or other requirement or rule of any federal, state, local or foreign government or political subdivision thereof, or any arbitrator, court or tribunal of competent jurisdiction.
- 1.20. “**Loss**” means any and all losses, damages, liabilities, deficiencies, claims, actions, judgments, settlements, interest, awards, penalties, fines, costs or expenses of whatever kind, including reasonable attorneys’ fees and the costs of enforcing any right to indemnification under the Agreement and the cost of pursuing any insurance providers.
- 1.21. “**Maintenance Release**” means any update, upgrade, release or other adaptation or modification of the Software, including any updated Documentation, that INdigital and/or any third party may provide to Customer from time to time during the Term, which may contain, among other things, error corrections, enhancements, improvements or other changes to the user interface, functionality, compatibility, capabilities, performance, efficiency or quality of the Software, but does not include any New Version.
- 1.22. “**New Version**” means any new version of the Software may from time to time be introduced and marketed generally as a distinct licensed product (as may be indicated by INdigital’s and/or a third party’s designation of a new version number), and which INdigital and/or a third party may make available to Customer at an additional cost under a separate written agreement.
- 1.23. “**Parties**” has the meaning set forth in the preamble to these Terms.
- 1.24. “**Party**” has the meaning set forth in the preamble to these Terms.
- 1.25. “**Payment Failure**” has the meaning set forth in Section 9.3(a) of these Terms.
- 1.26. “**Permitted Use**” has the meaning set forth in Section 6 of the Agreement.
- 1.27. “**Person**” means an individual, corporation, partnership, joint venture, limited liability entity, governmental authority, unincorporated organization, trust, association or other entity.
- 1.28. “**Receiving Party**” has the meaning set forth in Section 5.1 of these Terms.
- 1.29. “**Renewal Term**” has the meaning set forth in Section 9.2 of these Terms.
- 1.30. “**Representatives**” means, with respect to a Party, that Party’s employees, officers, directors, consultants, agents, independent contractors, service providers, sub licensees, subcontractors and legal advisors.
- 1.31. “**Software**” means the software listed in Exhibit C attached to, and incorporated by reference into, the Agreement, together with any Maintenance Releases provided to Customer pursuant to this Agreement.
- 1.32. “**Term**” has the meaning set forth in Section 9.2 of these Terms.
- 1.33. “**Territory**” has the meaning set forth in Section 5 of the Agreement.
- 1.34. “**Third-Party Materials**” means materials and information, in any form or medium, that are not proprietary to INdigital, including any third-party:
(a) documents, data, content or specifications; (b) software, hardware or other products, facilities, equipment or devices; and (c) accessories, components, parts or features of any of the foregoing.
- 1.35. “**Third-Party Payor**” means the **Illinois State Police 911 Administrative Support Command**.
- 1.36. “**Warranty Period**” has the meaning set forth in Section 10.2 of these Terms.
2. **LICENSE.**
- 2.1. **License Grant.** Subject to the terms and conditions of the Agreement (including these Terms) and INdigital’s rights under any third-party agreements relating to the Software, and conditioned on Customer’s and its Affiliates’ and Representatives’ compliance therewith, INdigital hereby grants to

EXHIBIT A
GENERAL TERMS AND CONDITIONS
(9-1-1 SERVICES AND SOFTWARE LICENSE)

Customer a non-exclusive, non-sub licensable and non-transferable, limited license and sublicense (to the extent allowed by any third-party agreements) to use the Software and Documentation solely for the Permitted Use in the Territory during the Term.

2.2. Scope of Licensed Access and Use. Customer may use and run one copy of the Software on, Customer's network at any of the Designated Site(s), across, and between – as specified in Exhibits C & D hereto – the networks of: a) Customer at any of the Designated Site(s); b) INdigital; and c) Rock Island. The total number of Designated Site(s) shall not exceed the number set forth under the Agreement (including these Terms), except as expressly agreed to in writing by the Parties and subject to any appropriate adjustment of the license fees payable under the Agreement.

3. USE RESTRICTIONS. Except as the Agreement (including these Terms) expressly permits, Customer shall not, and shall not permit any other Person to:

- 3.1. copy the Software, in whole or in part;
- 3.2. modify, correct, adapt, translate, enhance or otherwise prepare derivative works or improvements of any Software;
- 3.3. rent, lease, lend, sell, sublicense, assign, distribute, publish, transfer or otherwise make available the Software to any Person, including on or in connection with the internet or any time-sharing, service bureau, software as a service, cloud or other technology or service;
- 3.4. reverse engineer, disassemble, decompile, decode or adapt the Software, or otherwise attempt to derive or gain access to the source code of the Software, in whole or in part;
- 3.5. bypass or breach any security device or protection used for or contained in the Software or Documentation;
- 3.6. remove, delete, efface, alter, obscure, translate, combine, supplement or otherwise change any trademarks, terms of the Documentation, warranties, disclaimers, or Intellectual Property Rights, proprietary rights or other symbols, notices, marks or serial numbers on or relating to any copy of the Software or Documentation;
- 3.7. use the Software in any manner or for any purpose that infringes, misappropriates or otherwise violates any Intellectual Property Right or other right of any Person, or that violates any applicable Law;
- 3.8. use the Software for purposes of:

(i) benchmarking or competitive analysis of the Software; (ii) developing, using or providing a competing software product or service; or (iii) any other purpose that is to INdigital's detriment or commercial disadvantage;

3.9. use the Software in or in connection with the design, construction, maintenance, operation or use of any hazardous environments, systems or applications, any safety response systems or other safety-critical applications, or any other use or application in which the use or failure of the Software could lead to personal injury or severe physical or property damage; or

3.10. use the Software or Documentation other than for the Permitted Use or in any manner or for any purpose or application not expressly permitted by the Agreement (including these Terms).

4. DELIVERY AND INSTALLATION. INdigital shall deliver and install one copy of the Software for Customer. Risk of loss of any tangible media on which the Software is delivered shall pass to Customer on delivery.

4.1. Acceptance. Customer will test whether the Software operates in accordance with the Documentation ("**Acceptance Testing**") pursuant to the terms of this Section 4. Upon completion of the Software installation, Customer shall have fourteen (14) days to test the Software and notify INdigital in writing of any defect or deficiency. If the initial Acceptance Testing fails, INdigital shall, within fifteen (15) days of the Acceptance Testing and at its cost, correct the errors so disclosed and Customer may repeat the Acceptance Testing. If the subsequent Acceptance Testing fails, and such failure does not arise from or relate to any failure or defect of Customer's or any third-party's product, service, hardware, software, system or network, INdigital shall, within fifteen (15) days of the subsequent Acceptance Testing, at its cost, correct the errors so disclosed and Customer may again repeat the Acceptance Testing. If the subsequent Acceptance Testing fails two (2) or more times, Customer may terminate the Agreement (including these Terms) on written notice to INdigital. On termination, INdigital shall refund all license fees paid by Customer under the Agreement (including these Terms) within thirty (30) days of receipt of such notice, and such refund shall be Customer's sole and exclusive remedy for any unresolved Acceptance Testing failures. In any event, Customer shall be deemed to have accepted the Software if: (a) the Acceptance Testing is certified by Customer to be successful; or (b) Customer commences operational use of the Software.

EXHIBIT A
GENERAL TERMS AND CONDITIONS
(9-1-1 SERVICES AND SOFTWARE LICENSE)

4.2. MAINTENANCE AND SUPPORT. During the Term, INdigital: (i) will comply with the relevant law's requirements for 9-1-1 System Provider(s) and perform their work hereunder in a manner such that Customer shall be in compliance with relevant law; (ii) use commercially reasonable efforts to resolve any Incidents reported by Customer; (iii) will provide Customer with all Maintenance Releases under the terms and conditions set forth in the Software License Agreement. An "Incident", as used herein and throughout these Terms, means a support request that begins when Customer contacts INdigital to report a specific Error and ends when INdigital either:

(a) resolves the Error; or (b) determines in its conjunction with Customer that the Error cannot be resolved. INdigital will use commercially reasonable efforts to resolve an incident but does not guarantee that any Incident will be resolved. In the event that an Incident cannot be resolved, INdigital and Customer will arrange a mutually agreed upon alternative for avoiding future occurrences of the Error.

As set forth above, during the Term, INdigital will provide Customer with all Maintenance Releases (including updated Documentation) that INdigital may, in its sole discretion, make generally available to its licensees at no additional charge. All Maintenance Releases, being provided by INdigital to Customer under the Agreement, are deemed Software subject to all applicable terms and conditions in the Agreement (including these Terms). As part of the support and maintenance to be provided by INdigital to Customer, Customer will install all Maintenance Releases as soon as practicable after receipt. Customer does not have any right under the Agreement to receive any New Versions of the Software that INdigital or any third-party software provider may, in its sole discretion, release from time to time. Customer may license any New Version at INdigital's then-current list price and subject to a separate license agreement, provided that Customer is in compliance with the terms and conditions of the Agreement (including these Terms).

5. CONFIDENTIALITY.

5.1. Confidential Information. In connection with the Agreement each Party (as the "Disclosing Party") may disclose or make available to the other Party (as the "Receiving Party") Confidential Information. Subject to Section 5.2 of these Terms, "Confidential Information" means information in any form or medium (whether oral, written, electronic or other) that the Disclosing Party considers confidential or proprietary, including information consisting of or relating to the Disclosing Party's technology, trade secrets, know-how, business operations, plans, strategies, customers, and pricing, and information

with respect to which the Disclosing Party has contractual or other confidentiality obligations, whether or not marked, designated or otherwise identified as "confidential". Without limiting the foregoing: (a) the Software and Documentation are the Confidential Information of INdigital; and (b) the financial terms of the Agreement (including these Terms) are the Confidential Information of INdigital.

5.2. Exclusions and Exceptions. Confidential Information does not include information that the Receiving Party can demonstrate by written or other documentary records: (a) was rightfully known to the Receiving Party without restriction on use or disclosure prior to such information's being disclosed or made available to the Receiving Party in connection with the Agreement (including these Terms); (b) was or becomes generally known by the public other than by the Receiving Party's or any of its Representatives' noncompliance with the Agreement (including these Terms); (c) was or is received by the Receiving Party on a non-confidential basis from a third party that was not or is not, at the time of such receipt, under any obligation to maintain its confidentiality; or (d) the Receiving Party can demonstrate by written or other documentary records was or is independently developed by the Receiving Party without reference to or use of any Confidential Information.

5.3. Protection of Confidential Information. As a condition to being provided with any disclosure of or access to Confidential Information, the Receiving Party shall:

(a) not access or use Confidential Information other than as necessary to exercise its rights or perform its obligations under and in accordance with the Agreement (including these Terms);

(b) except as may be permitted under the terms and conditions of Section 6.4 of these Terms, not disclose or permit access to Confidential Information other than to Rock Island, the Illinois State Police 9-1-1 Administrative Support Command, or the Receiving Party's Representatives who: (i) need to know such Confidential Information for purposes of the Receiving Party's exercise of its rights or performance of its obligations under and in accordance with the Agreement (including these Terms); (ii) have been informed of the confidential nature of the Confidential Information and the Receiving Party's obligations under this Section 5; and (iii) are bound by written confidentiality and restricted use obligations at least as protective of the Confidential Information as the terms set forth in this Section 5;

EXHIBIT A
GENERAL TERMS AND CONDITIONS
(9-1-1 SERVICES AND SOFTWARE LICENSE)

(c) safeguard the Confidential Information from unauthorized use, access or disclosure using at least the degree of care it uses to protect its similarly sensitive information and in no event less than a reasonable degree of care;

(d) promptly notify the Disclosing Party of any unauthorized use or disclosure of Confidential Information and cooperate with Disclosing Party to prevent further unauthorized use or disclosure; and

(e) ensure its Representatives' compliance with and be responsible and liable for any of its Representatives' non-compliance with, the terms of this Section 5.

Notwithstanding any other provisions of the Agreement (including these Terms), the Receiving Party's obligations under this Section 5 with respect to any Confidential Information that constitutes a trade secret under any applicable Law will continue until such time, if ever, as such Confidential Information ceases to qualify for trade secret protection under one or more such applicable Laws other than as a result of any act or omission of the Receiving Party or any of its Representatives.

5.4. Compelled Disclosures. If the Receiving Party or any of its Representatives is compelled by applicable Law to disclose any Confidential Information then, to the extent permitted by applicable Law, the Receiving Party shall: (a) promptly, and prior to such disclosure, notify the Disclosing Party in writing of such requirement so that the Disclosing Party can seek a protective order or other remedy or waive its rights under Section 5.3 of these Terms; and (b) provide reasonable assistance to the Disclosing Party, at the Disclosing Party's sole cost and expense, in opposing such disclosure or seeking a protective order or other limitations on disclosure. If the Disclosing Party waives compliance or, after providing the notice and assistance required under this Section 5.4, the Receiving Party remains required by Law to disclose any Confidential Information, the Receiving Party shall disclose only that portion of the Confidential Information that the Receiving Party is legally required to disclose and, on the Disclosing Party's request, shall use commercially reasonable efforts to obtain assurances from the applicable court or other presiding authority that such Confidential Information will be afforded confidential treatment.

5.5. Return; Destruction. Confidential Information will remain the property of the Disclosing Party and will, at the Disclosing Party's request and after it is no longer needed for the purposes of the Agreement (including these Terms) or upon expiration or

termination of the Agreement (including these Terms) for any reason, whichever occurs first, promptly be returned to the Disclosing Party or be destroyed, together with all copies made by the Receiving Party and by anyone to whom such Confidential Information has been made available by the Receiving Party in accordance with the provisions of this section.

6. FEES AND PAYMENT.

6.1. License Fees. In consideration of the rights granted to Customer under the Agreement (including these Terms), Customer shall pay to INdigital the license fees set forth in Exhibit D (attached to, and incorporated by reference into, the Agreement) in accordance with that exhibit and the terms of this Section 7. If the Term is renewed for any Renewal Term(s) pursuant to Section 9.2 of these Terms, Customer shall pay the then-current standard license fees that INdigital charges for the Software during the applicable Renewal Term.

6.2. Additional Fees and Expenses. In consideration of INdigital providing installation, support and maintenance, training, and other ancillary services under the Agreement (including these Terms), Customer shall pay to INdigital the fees set forth in Exhibit D attached to, and incorporated by reference into, the Agreement.

6.3. Taxes. All license fees and other amounts payable by Customer under the Agreement (including these Terms) are exclusive of taxes and similar assessments. Without limiting the foregoing, Customer is responsible for all sales, service, use and excise taxes, and any other similar taxes, duties and charges of any kind imposed by any federal, state or local governmental or regulatory authority on any amounts payable by Customer under the Agreement, other than any taxes imposed on INdigital's income.

6.4. Payment Obligation. The Third-Party Payor shall be solely responsible for the payment of those items which are listed on Exhibit D with an asterisk (*) symbol together with any other cost which is, from time to time, required by Illinois State law. Customer shall be responsible for other costs specified by this contract.

6.5. Payment. Customer shall pay all amounts due and owing under the Agreement (including these Terms) within thirty 30 days after the date of INdigital's invoice therefor. Customer shall make all payments under the Agreement in US dollars by wire transfer or check to the address or account specified in Exhibit D attached to, and incorporated by reference into, the Agreement or such other address or account as INdigital may specify in writing from time to time.

EXHIBIT A
GENERAL TERMS AND CONDITIONS
(9-1-1 SERVICES AND SOFTWARE LICENSE)

Notwithstanding the foregoing, Customer shall not be responsible for amounts billed directly to the Illinois State Police 9-1-1 Administrative Support Command.

6.6. Late Payment by Customer. If Customer fails to make any payment, for which it is responsible, when due then, in addition to all other remedies that may be available to INdigital:

(a) INdigital may charge interest on the past due amount at the rate of 1.5% per month calculated daily and compounded monthly or, if lower, the highest rate permitted under applicable Law;

(b) Customer shall reimburse INdigital for all reasonable costs incurred by INdigital in collecting any late payment of amounts due or related interest, including attorneys' fees, court costs and collection agency fees. Notwithstanding the foregoing, Customer shall not be responsible for amounts billed directly to the Illinois State Police 9-1-1 Administrative Support Command; and

(c) if such failure continues for thirty (30) days following written notice thereof, INdigital may, following a further six (6) month notice: (i) disable Customer's use of the Software (including by means of a disabling code, technology or device); (ii) withhold, suspend or revoke its grant of a license and/or sublicense under the Agreement; and/or (iii) terminate the Agreement (including these Terms) under Section 9.3(a) or Section 9.3(b) of these Terms, as applicable. INdigital shall cooperate with Customer and Customer's selected subsequent provider to facilitate an orderly transition.

6.7. Late Payment by Third-Party Payor. If Third-Party Payor fails to make any payment, for which it is responsible, when due then, in addition to all other remedies that may be available to INdigital, if such failure continues for thirty (30) days following written notice thereof to Customer and to Third-Party Payor, INdigital may, following a further six (6) month notice to Customer and Third-Party Payor: (i) disable Customer's use of the Software (including by means of a disabling code, technology or device); (ii) withhold, suspend or revoke its grant of a license and/or sublicense under the Agreement; and/or (iii) terminate the Agreement (including these Terms) under Section 9.3(a) or Section 9.3(b) of these Terms, as applicable. INdigital shall cooperate with Customer and Customer's selected subsequent provider to facilitate an orderly transition.

6.8. No Deductions or Setoffs. All undisputed

amounts payable to INdigital under the Agreement (including these Terms) by Customer shall be paid by Customer to INdigital in full without any setoff, recoupment, counterclaim, deduction, debit or withholding for any reason (other than any deduction or withholding of tax as may be required by applicable Law). Disputed amounts may be withheld until the associated dispute is resolved.

7. **SECURITY MEASURES.** The Software may contain technological measures designed to prevent unauthorized or illegal use of the Software. Customer acknowledges and agrees that: (a) INdigital may use these and other lawful measures to verify Customer's compliance with the terms of the Agreement (including these Terms) and enforce INdigital's rights, including all Intellectual Property Rights, in and to the Software; (b) INdigital may deny any individual access to and/or use of the Software if INdigital, in its sole reasonable discretion, believes that Person's use of the Software would violate any provision of the Agreement (including these Terms); and (c) INdigital and its Representatives may collect, maintain, process and use diagnostic, technical, usage and related information, including information about Customer's computers, systems and software, that INdigital may gather periodically to improve the performance of the Software or develop Maintenance Releases. This information will be treated in accordance with INdigital's privacy policy, as amended from time to time.

8. **INTELLECTUAL PROPERTY RIGHTS.**

8.1. Intellectual Property Ownership. Customer acknowledges and agrees that:

(a) the Software and Documentation are licensed or sublicensed and not sold to Customer by INdigital and Customer does not and will not have or acquire under or in connection with the Agreement (including these Terms) any ownership interest in the Software or Documentation, or in any related Intellectual Property Rights;

(b) INdigital and its licensor(s) are and will remain the sole and exclusive owners of all right, title and interest in and to the Software and Documentation, including all Intellectual Property Rights relating thereto, subject only to the limited license granted to Customer under the Agreement; and

(c) Customer hereby unconditionally and irrevocably assigns to INdigital or INdigital's designee, Customer's entire right, title and interest in and to any Intellectual Property Rights

EXHIBIT A
GENERAL TERMS AND CONDITIONS
(9-1-1 SERVICES AND SOFTWARE LICENSE)

that Customer may now or hereafter have in or relating to the Software or Documentation (including any rights in derivative works or patent improvements relating to either of them), whether held or acquired by operation of law, contract, assignment or otherwise.

8.2. Customer Cooperation and Notice of Infringement. Customer shall, during the Term:

- (a) take all reasonable measures to safeguard the Software and Documentation (including all copies thereof) from infringement, misappropriation, theft, misuse or unauthorized access;
- (b) at INdigital's expense, take all such steps as INdigital may reasonably require to assist INdigital in maintaining the validity, enforceability and INdigital's ownership of the Intellectual Property Rights in the Software and Documentation;
- (c) promptly notify INdigital in writing if Customer becomes aware of:
 - (i) any actual or suspected infringement, misappropriation or other violation of INdigital's Intellectual Property Rights in or relating to the Software or Documentation; or
 - (ii) any claim that the Software or Documentation, including any production, use, marketing, sale or other disposition of the Software or Documentation, in whole or in part, infringes, misappropriates or otherwise violates the Intellectual Property Rights or other rights of any Person; and
- (d) at INdigital's expense, fully cooperate with and assist INdigital in all reasonable ways in the conduct of any claim, suit, action or proceeding (each, an "Action") by INdigital to prevent or abate any actual or threatened infringement, misappropriation or violation of INdigital's rights in, and to attempt to resolve any claims relating to, the Software or Documentation.

8.3. No Implied Rights. Except for the limited rights and licenses expressly granted under the Agreement, nothing in the Agreement (including these Terms) grants, by implication, waiver, estoppel or otherwise, to Customer or any third party any Intellectual Property Rights or other right, title, or interest in or to any of the Software or Documentation.

9. TERM AND TERMINATION.

9.1. Initial Term. Subject to the Third Party Payor's approval of the modification plan as required IL Ad. Code Title 83, Ch. IV, Part 1325, the initial term of the Agreement commences as of the Effective Date and will continue in effect until such time as specified in Section 11 of the Agreement, unless terminated earlier pursuant to any of the Agreement's express provisions (the "Initial Term").

9.2. Renewal Term. The Agreement will automatically renew for additional successive terms specified in Section 11 of the Agreement unless earlier terminated pursuant to any of the Agreement's express provisions or either Party gives the other Party written notice of non-renewal at least ninety (90) days prior to the expiration of the then-current term (each, a "Renewal Term" and, collectively, together with the Initial Term, the "Term").

9.3. Termination. The Agreement may be terminated at any time:

- (a) by INdigital, effective on written notice to Customer, if Customer fails to pay any amount for which it is responsible when due under the Agreement (including these Terms), where such failure continues more than thirty (30) days after INdigital's delivery of written notice thereof ("Payment Failure");
- (b) by INdigital, on written notice to Customer if any two or more Payment Failures occur in any 12-month period;
- (c) by either Party, effective on written notice to the other Party, if the other Party materially breaches the Agreement (including these Terms) and such breach: (i) is incapable of cure; or (ii) being capable of cure, remains uncured thirty (30) days after the non-breaching Party provides the breaching Party with written notice of such breach (except in the case of a Payment Failure, which shall be governed by Section 9.3(a) of these Terms);
- (d) by INdigital, if the Customer: (i) is dissolved or liquidated or takes any corporate action for such purpose; (ii) becomes insolvent or is generally unable to pay its debts as they become due; (iii) becomes the subject of any voluntary or involuntary bankruptcy proceeding under any domestic or foreign bankruptcy or insolvency Law; (iv) makes or seeks to make a general assignment for the benefit of its creditors; or (v) applies for, or consents to, the appointment of a trustee, receiver or custodian for a substantial part of its property;
- (e) by INdigital, upon notice to Customer, if

EXHIBIT A
GENERAL TERMS AND CONDITIONS
(9-1-1 SERVICES AND SOFTWARE LICENSE)

Customer is in breach of any other agreement between the Parties and such breach is not cured pursuant to the terms of such agreement.

(f) In the event the Agreement is terminated under this Section 9.3, INdigital shall cooperate with Customer and Customer's selected subsequent provider for the following 6 months from written notice of said termination for purpose of transitioning emergency telephone services.

9.4. Materiality. INdigital's failure to comply with paragraph 4.2(i) shall be a material breach.

9.5. Effect of Termination or Expiration. On the expiration or earlier termination of the Agreement:

(a) all rights, licenses and authorizations granted to Customer under the Agreement will immediately terminate and Customer shall:

(i) immediately cease all use of and other activities with respect to the Software and Documentation other than those described in Section 9.4(a)(ii) of these Terms;

(ii) within sixty (60) days deliver to INdigital, or at INdigital's written request destroy, and permanently erase from all devices and systems Customer directly or indirectly controls, the Software, the Documentation and INdigital's Confidential Information, including all documents, files and tangible materials (and any partial and complete copies) containing, reflecting, incorporating or based on any of the foregoing, whether or not modified or merged into other materials;

(iii) certify to INdigital in a signed written instrument that it has complied with the requirements of this Section 9.4; and

(b) all amounts payable by Customer to INdigital of any kind under the Agreement (including these Terms) are immediately payable and due no later than thirty (30) days after the effective date of the expiration or INdigital's termination of the Agreement.

9.6. Surviving Terms. The provisions set forth in the following sections, and any other right, obligation or provision under the Agreement (including these Terms) that, by its nature, should survive termination or expiration of the Agreement (including these Terms), will survive any expiration or termination of the Agreement: this Section 9.5 of these Terms, Section 1 of these Terms (Definitions), Section 5 of

these Terms (Confidentiality), Section 8 of these Terms (Intellectual Property Rights), Section 10 of these Terms (Representations and Warranties), for clarity, including Section 10.7 of these Terms (Disclaimer), Section 11 of these Terms (Indemnification), Section 12 of these Terms (Limitations of Liability), and Section 15 of these Terms (Miscellaneous).

10. REPRESENTATIONS AND WARRANTIES.

10.1. Mutual Representations and Warranties. Each Party represents, warrants and covenants to the other Party that:

(a) it has the full right, power and authority to enter into and perform its obligations and grant the rights, licenses and authorizations it grants and is required to grant under the Agreement (including these Terms);

(b) the execution of the Agreement by its representative whose signature is set forth at the end of the Agreement has been duly authorized by all necessary action of such Party; and

(c) when executed and delivered by both Parties, the Agreement (including these Terms) will constitute the legal, valid and binding obligation of such Party, enforceable against such Party in accordance with its terms.

10.2. Limited Warranty. Subject to the limitations and conditions set forth in Section 10.3 of these Terms and Section 10.4 of these Terms, INdigital warrants to Customer that for a period of **365 days** from the **Effective Date** (the "**Warranty Period**"), the Software will substantially conform in all material respects to the specifications set forth in the Documentation, when installed, operated and used as recommended in the Documentation and in accordance with the Agreement (including these Terms).

10.3. Customer Requirements. The limited warranty set forth in Section 10.2 of these Terms applies only if Customer: (a) notifies INdigital in writing of the warranty breach before the expiration of the Warranty Period; (b) has promptly installed all Maintenance Releases to the Software that INdigital previously made available to Customer; and (c) as of the date of notification, is in compliance with all terms and conditions of the Agreement (including these Terms) (including the payment of all license fees then due and owing).

10.4. Exceptions. Notwithstanding any provisions to the contrary in the Agreement (including these Terms), the limited warranty set forth in Section

EXHIBIT A
GENERAL TERMS AND CONDITIONS
(9-1-1 SERVICES AND SOFTWARE LICENSE)

10.2 of these Terms does not apply to problems arising out of or relating to:

- (a) Software, or the media on which it is provided, that is modified or damaged by Customer or its Representatives;
- (b) any operation or use of, or other activity relating to, the Software other than as specified in the Documentation, including any incorporation in the Software of, or combination, operation or use of the Software in or with, any technology (including any software, hardware, firmware, system or network) or service not specified for Customer's use in the Documentation, unless otherwise expressly permitted by INdigital in writing;
- (c) Customer's or any third party's negligence, abuse, misapplication or misuse of the Software, including any use of the Software other than as specified in the Documentation or expressly authorized by INdigital in writing;
- (d) Customer's failure to promptly install all Maintenance Releases that INdigital has previously made available to Customer;
- (e) the operation of, or access to, Customer's or a third party's system or network;
- (f) any beta software, software that INdigital makes available for testing or demonstration purposes, temporary software modules or software for which INdigital does not receive a license fee;
- (g) Customer's material breach of any provision of the Agreement (including these Terms);
- (h) any other circumstances or causes outside of the reasonable control of INdigital (including abnormal physical or electrical stress); or
- (i) any failure or interruption of any electrical power, or any accident or cause external to the Software, including, but not limited to, problems or malfunctions related to Customer's network, database, third party software products, workstation configurations, Customer's hardware, operator error, or Customer's negligence or willful misconduct.

10.5. Remedial Efforts. If INdigital breaches, or is alleged to have breached, the limited warranty set forth in Section 10.2 of these Terms, INdigital may, at its sole option and expense, take any of the following steps to remedy such breach:

- (a) replace any damaged or defective media on which INdigital supplied the Software;
- (b) amend, supplement or replace any incomplete or inaccurate Documentation;
- (c) repair the Software;
- (d) replace the Software with functionally equivalent software (which software will, on its replacement of the Software, constitute Software); and/or
- (e) terminate the Agreement and, provided that Customer fully complies with all of its post-termination obligations as set forth in Section 9.4 of these Terms, promptly refund to Customer, on a *pro rata* basis, the share of any license fees prepaid by Customer for the future portion of the Term that would have remained but for such termination.

10.6. Sole Remedy. If INdigital does not cure a warranty breach or terminate the Agreement as provided in Section 10.5 of these Terms within a reasonable period of time after INdigital's receipt of written notice of such breach, Customer shall have the right to terminate the Agreement as provided in Section 9.3(c) of these Terms. Provided that Customer fully complies with its post-termination obligations as set forth in Section 9.4 of these Terms, INdigital shall promptly refund to Customer, on a *pro rata* basis, the share of any license fees prepaid by Customer for the future portion of the Term that would have remained but for such termination. **THIS SECTION 10.6 SETS FORTH THE CUSTOMER'S SOLE REMEDY AND INDIGITAL'S ENTIRE OBLIGATION AND LIABILITY FOR ANY BREACH OF ANY INDIGITAL WARRANTY OF THE SOFTWARE SET FORTH IN THE AGREEMENT.**

10.7. DISCLAIMER OF WARRANTIES. EXCEPT FOR THE EXPRESS LIMITED WARRANTY SET FORTH IN SECTION 10.2 OF THESE TERMS, ALL SOFTWARE, DOCUMENTATION AND OTHER PRODUCTS, INFORMATION, MATERIALS AND SERVICES PROVIDED BY INDIGITAL ARE PROVIDED "AS IS." INDIGITAL HEREBY DISCLAIMS ALL WARRANTIES, WHETHER EXPRESS, IMPLIED, STATUTORY OR OTHER (INCLUDING ALL WARRANTIES ARISING FROM COURSE OF DEALING, USAGE OR TRADE PRACTICE), AND SPECIFICALLY DISCLAIMS ALL IMPLIED WARRANTIES OF MERCHANTABILITY, FITNESS FOR A PARTICULAR PURPOSE, TITLE AND NON-INFRINGEMENT. WITHOUT LIMITING THE FOREGOING, INDIGITAL

EXHIBIT A
GENERAL TERMS AND CONDITIONS
(9-1-1 SERVICES AND SOFTWARE LICENSE)

MAKES NO WARRANTY OF ANY KIND THAT THE SOFTWARE OR DOCUMENTATION, OR ANY OTHER INDIGITAL OR THIRD-PARTY GOODS, SERVICES, TECHNOLOGIES OR MATERIALS (INCLUDING ANY SOFTWARE OR HARDWARE), OR ANY PRODUCTS OR RESULTS OF THE USE OF ANY OF THEM, WILL MEET CUSTOMER'S OR OTHER PERSONS' REQUIREMENTS, OPERATE WITHOUT INTERRUPTION, ACHIEVE ANY INTENDED RESULT, BE COMPATIBLE OR WORK WITH ANY OTHER GOODS, SERVICES, TECHNOLOGIES OR MATERIALS (INCLUDING ANY SOFTWARE, HARDWARE, SYSTEM OR NETWORK), OR BE SECURE, ACCURATE, COMPLETE, FREE OF HARMFUL CODE OR ERROR FREE. ALL THIRD-PARTY MATERIALS ARE PROVIDED "AS IS" AND ANY REPRESENTATION OR WARRANTY OF OR CONCERNING ANY OF THEM IS STRICTLY BETWEEN CUSTOMER AND THE THIRD-PARTY OWNER OR DISTRIBUTOR OF SUCH OPEN- THIRD-PARTY MATERIALS.

11. INDEMNIFICATION.

11.1. INdigital Indemnification. INdigital shall indemnify, defend and hold harmless Customer from and against any and all Losses incurred by Customer arising out of or relating to any Action by a third party (other than an Affiliate) to the extent that such Losses arise from any allegation in such Action that the Software, or any use of the Software, in the Territory in accordance with the Agreement (including these Terms) (including the Documentation) infringes any U.S. Intellectual Property Right in the U.S. The foregoing obligation does not apply to the extent that such Action or Losses arise from any allegation of or relating to any:

- (a) Third-Party Materials;
- (b) patent issued on a patent application published after the Effective Date;
- (c) incorporation by the Software of, or combination, operation or use of the Software in or with, any technology (including any software, hardware, firmware, system or network) or service not provided by INdigital or specified for Customer's use in the Documentation, unless otherwise expressly permitted by INdigital in writing;
- (d) modification of the Software other than:
 - (i) by INdigital or its authorized contractor in connection with the Agreement (including these Terms); or
 - (ii) with INdigital's express written

authorization and in strict accordance with INdigital's written directions and specifications;

- (e) failure to timely implement any Maintenance Release, modification, update or replacement of the Software made available to Customer by INdigital;
- (f) use of the Software after INdigital's notice to Customer of such activity's alleged or actual infringement, misappropriation or other violation of a third party's rights;
- (g) negligence, abuse, misapplication or misuse of the Software or Documentation by or on behalf of Customer, Customer's Representatives or a third party;
- (h) use of the Software or Documentation by or on behalf of Customer that is outside the purpose, scope or manner of use authorized by the Agreement (including these Terms) or in any manner contrary to INdigital's instructions;
- (i) events or circumstances outside of INdigital's commercially reasonable control (including any third-party hardware, software or system bugs, defects or malfunctions); or
- (j) Action or Losses for which Customer is obligated to indemnify INdigital pursuant to Section 11.2 of these Terms.

11.2. Customer Indemnification. Customer shall indemnify, defend and hold harmless INdigital and its Affiliates, officers, directors, employees, agents, subcontractors, successors and assigns (each, including INdigital, an "**INdigital Indemnitee**") from and against any and all Losses incurred by the INdigital Indemnitee in connection with any Action by a third party (other than an Affiliate of a INdigital Indemnitee) to the extent that such Losses arise out of or relate to any allegation:

- (a) that any Intellectual Property Right or other right of any Person, or any Law, is or will be infringed, misappropriated or otherwise violated by any:
 - (i) use or combination of the Software by or on behalf of Customer or any of its Representatives with any hardware, software, system, network, service or other matter whatsoever that is neither provided by INdigital nor authorized by INdigital in the Agreement (including these Terms) and the Documentation or otherwise in writing; and
 - (ii) information, materials or

EXHIBIT A
GENERAL TERMS AND CONDITIONS
(9-1-1 SERVICES AND SOFTWARE LICENSE)

technology or other matter whatsoever directly or indirectly provided by Customer or directed by Customer to be installed, combined, integrated or used with, as part of, or in connection with the Software or Documentation;

(b) of or relating to facts that, if true, would constitute a breach by Customer of any representation, warranty, covenant or obligation under the Agreement (including these Terms);

(c) of or relating to negligence, abuse, misapplication, misuse or more culpable act or omission (including recklessness or willful misconduct) by or on behalf of Customer or any of its Representatives with respect to the Software or Documentation or otherwise in connection with the Agreement (including these Terms); or

(d) of or relating to use of the Software or Documentation by or on behalf of Customer or any of its Representatives that is outside the purpose, scope or manner of use authorized by the Agreement (including these Terms) or the Documentation, or in any manner contrary to INdigital's instructions.

11.3. Indemnification Procedure. Each Party shall promptly notify the other Party in writing of any Action for which such Party believes it is entitled to be indemnified pursuant to Section 11.1 or Section 11.2 of these Terms. The Party seeking indemnification (the "**Indemnitee**") shall cooperate with the other Party (the "**Indemnitor**") at the Indemnitor's sole cost and expense. The Indemnitor shall immediately take control of the defense and investigation of such Action and shall employ counsel reasonably acceptable to the Indemnitee to handle and defend the same, at the Indemnitor's sole cost and expense. The Indemnitee's failure to perform any obligations under this Section 11 will not relieve the Indemnitor of its obligations under this Section 11 except to the extent that the Indemnitor can demonstrate that it has been materially prejudiced as a result of such failure. The Indemnitee may participate in and observe the proceedings at its own cost and expense with counsel of its own choosing.

11.4. Mitigation. If the Software, or any part of the Software, is, or in INdigital's opinion is likely to be, claimed to infringe, misappropriate or otherwise violate any third-party Intellectual Property Right, or if Customer's use of the Software is enjoined or threatened to be enjoined, INdigital may, at its option and sole cost and expense:

(a) obtain the right for Customer to continue

to use the Software materially as contemplated by the Agreement (including these Terms);

(b) modify or replace the Software, in whole or in part, to seek to make the Software non-infringing, while providing materially equivalent features and functionality, and such modified or replacement software will constitute Software under the Agreement (including these Terms); or

(c) if none of the remedies set forth in the above Section 11.4(a) or Section 11.4(b) of these Terms is reasonably available to INdigital, terminate the Agreement, in its entirety or with respect to the affected part or feature of the Software, effective immediately on written notice to Customer, in which event:

(i) immediately on receipt of INdigital's notice, Customer shall cease all use of the Software and Documentation immediately on receipt of Customer's notice; and

(ii) provided that Customer fully complies with its post-termination obligations set forth in Section 9.4 of these Terms, INdigital shall promptly refund to Customer, on a *pro rata* basis, the share of any license fees prepaid by Customer for the future portion of the Term that would have remained but for such termination.

11.5. Sole Remedy. THIS SECTION 11 SETS FORTH CUSTOMER'S SOLE REMEDIES AND INDIGITAL'S SOLE LIABILITY AND OBLIGATION FOR ANY ACTUAL, THREATENED OR ALLEGED CLAIMS THAT THE AGREEMENT (INCLUDING THESE TERMS) OR ANY SUBJECT MATTER OF THE AGREEMENT (INCLUDING THE SOFTWARE AND DOCUMENTATION) INFRINGES, MISAPPROPRIATES OR OTHERWISE VIOLATES ANY INTELLECTUAL PROPERTY RIGHTS OF ANY THIRD PARTY.

12. LIMITATION OF LIABILITY.

12.1. EXCLUSION OF DAMAGES. IN NO EVENT WILL INDIGITAL OR ANY OF ITS LICENSORS, SERVICE PROVIDERS OR SUPPLIERS BE LIABLE UNDER OR IN CONNECTION WITH THE AGREEMENT (INCLUDING THESE TERMS) OR ITS SUBJECT MATTER UNDER ANY LEGAL OR EQUITABLE THEORY, INCLUDING BREACH OF CONTRACT, TORT (INCLUDING NEGLIGENCE), STRICT LIABILITY AND OTHERWISE, FOR ANY (a) INCREASED COSTS, DIMINUTION IN VALUE

EXHIBIT A
GENERAL TERMS AND CONDITIONS
(9-1-1 SERVICES AND SOFTWARE LICENSE)

OR LOST BUSINESS, PRODUCTION, REVENUES OR PROFITS, (b) LOSS OF GOODWILL OR REPUTATION, (c) USE, INABILITY TO USE, LOSS, INTERRUPTION, DELAY OR RECOVERY OF ANY SOFTWARE OR THIRD-PARTY MATERIALS, (d) LOSS, DAMAGE, CORRUPTION OR RECOVERY OF DATA, OR BREACH OF DATA OR SYSTEM SECURITY, (e) COST OF REPLACEMENT GOODS OR SERVICES, OR (f) CONSEQUENTIAL, INCIDENTAL, INDIRECT, EXEMPLARY, SPECIAL, ENHANCED OR PUNITIVE DAMAGES, IN EACH CASE REGARDLESS OF WHETHER SUCH PERSONS WERE ADVISED OF THE POSSIBILITY OF SUCH LOSSES OR DAMAGES OR SUCH LOSSES OR DAMAGES WERE OTHERWISE FORESEEABLE, AND NOTWITHSTANDING THE FAILURE OF ANY AGREED OR OTHER REMEDY OF ITS ESSENTIAL PURPOSE.

12.2. CAP ON MONETARY LIABILITY.

IN NO EVENT WILL THE AGGREGATE LIABILITY OF INDIGITAL AND ITS LICENSORS, SUPPLIERS AND SERVICE PROVIDERS ARISING OUT OF OR RELATED TO THE AGREEMENT (INCLUDING THESE TERMS), WHETHER ARISING UNDER OR RELATED TO BREACH OF CONTRACT, TORT (INCLUDING NEGLIGENCE), STRICT LIABILITY OR ANY OTHER LEGAL OR EQUITABLE THEORY, EXCEED THE TOTAL AMOUNTS PAID TO INDIGITAL UNDER THE AGREEMENT IN THE 12-MONTH PERIOD PRECEDING THE EVENT GIVING RISE TO THE CLAIM. THE FOREGOING LIMITATIONS APPLY EVEN IF ANY REMEDY FAILS OF ITS ESSENTIAL PURPOSE.

- 13. EXPORT REGULATION.** Customer shall not itself, or permit any other Person to, export, re-export or release, directly or indirectly any Controlled Technology to any country, jurisdiction or Person to which the export, re-export or release of Controlled Technology (a) is prohibited by applicable Law or (b) without first completing all required undertakings (including obtaining any necessary export license).

14. FORCE MAJEURE.

14.1. No Breach or Default. In no event will INDigital be liable or responsible to Customer, or be deemed to have defaulted under or breached the Agreement (including these Terms), for any failure or delay in fulfilling or performing any term of the Agreement (including these Terms), when and to the extent such failure or delay is caused by any circumstances beyond INDigital's reasonable control

(a "Force Majeure Event"), including acts of God, flood, fire, earthquake or explosion, war, terrorism, invasion, riot or other civil unrest, embargoes or blockades in effect on or after the date of the Agreement, national or regional emergency, strikes, labor stoppages or slowdowns or other industrial disturbances, passage of Law or any action taken by a governmental or public authority, including imposing an export or import restriction, quota or other restriction or prohibition or any complete or partial government shutdown, or national or regional shortage of adequate power or telecommunications or transportation. Either Party may terminate the Agreement if a Force Majeure Event continues substantially uninterrupted for a period of 90 days or more.

14.2. Obligations. In the event of any failure or delay caused by a Force Majeure Event, INDigital shall give prompt written notice to Customer stating the period of time the occurrence is expected to continue and use commercially reasonable efforts to end the failure or delay and minimize the effects of such Force Majeure Event.

15. MISCELLANEOUS.

15.1. Further Assurances. On a Party's reasonable request, the other Party shall, at the requesting Party's sole cost and expense, execute and deliver all such documents and instruments, and take all such further actions, as may be necessary to give full effect to the Agreement.

15.2. Relationship of the Parties. The relationship between the Parties is that of independent contractors. Nothing contained in the Agreement (including these Terms) shall be construed as creating any agency, partnership, joint venture or other form of joint enterprise, employment or fiduciary relationship between the Parties, and neither Party shall have authority to contract for or bind the other Party in any manner whatsoever.

15.3. Notices. Except as otherwise expressly set forth in the Agreement, any notice, request, consent, claim, demand, waiver or other communication under the Agreement will have legal effect only if in writing and addressed to a Party at its address or e-mail designated in the Agreement. Notices sent in accordance with this Section 15.3 will be deemed effectively given: (i) when received, if delivered by hand, with signed confirmation of receipt; (ii) when received, if sent by a nationally recognized overnight courier, signature required; (iii) when sent, if by facsimile or e-mail, (in each case, with confirmation of transmission), if sent during the addressee's normal business hours, and on the next

EXHIBIT A
GENERAL TERMS AND CONDITIONS
(9-1-1 SERVICES AND SOFTWARE LICENSE)

business day, if sent after the addressee's normal business hours; and (iv) on the third business day after the date mailed by certified or registered mail, return receipt requested, postage prepaid.

15.4. Interpretation. For purposes of the Agreement (including these Terms): (i) the words "include," "includes" and "including" are deemed to be followed by the words "without limitation"; (ii) the word "or" is not exclusive; (iii) the words "herein," "hereof," "hereby," "hereto" and "hereunder" refer to the Agreement as a whole (including these Terms); (iv) words denoting the singular have a comparable meaning when used in the plural, and vice versa; and (v) words denoting any gender include all genders. Unless the context otherwise requires, references in the Agreement (including these Terms): (x) to exhibits, exhibits, attachments and appendices mean the exhibits, exhibits, attachments and appendices attached to, the Agreement (including these Terms); (y) to an agreement, instrument or other document means such agreement, instrument or other document as amended, supplemented and modified from time to time to the extent permitted by the provisions thereof; and (z) to a statute means such statute as amended from time to time and includes any successor legislation thereto and any regulations promulgated thereunder. The Parties intend the Agreement (including these Terms) to be construed without regard to any presumption or rule requiring construction or interpretation against the party drafting an instrument or causing any instrument to be drafted. The exhibits, exhibits, attachments and appendices referred to in the Agreement (including these Terms) are an integral part of the Agreement to the same extent as if they were set forth verbatim in the Agreement.

15.5. Headings. The headings in the Agreement (including these Terms) are for reference only and do not affect the interpretation of the Agreement (including these Terms).

15.6. Entire Agreement. The Agreement, together with these Terms and any other documents incorporated by reference into the Agreement (and, if applicable, together with the Software Support and Maintenance Agreement), constitute the sole and entire agreement of the Parties with respect to the subject matter of the Agreement and supersede all prior and contemporaneous understandings, agreements, representations and warranties, both written and oral, with respect to such subject matter.

15.7. Assignment. Customer shall not assign or otherwise transfer any of its rights, or delegate or otherwise transfer any of its obligations or performance, under the Agreement (including these Terms) without INdigital's prior written consent. Any

purported assignment, delegation or transfer in violation of this Section 14.7 is void. The Agreement (including these Terms) inures to the benefit of, and is binding on and enforceable against, the Parties and their respective permitted successors and assigns.

15.8. No Third-Party Beneficiaries. The Agreement (including these Terms) are for the sole benefit of the Parties and their respective permitted successors and permitted assigns and nothing in the Agreement (including these Terms), express or implied, is intended to or shall confer on any other person or entity any legal or equitable right, benefit or remedy of any nature whatsoever under or by reason of the Agreement (including these Terms).

15.9. Amendment and Modification; Waiver. No amendment to, modification of, or rescission, termination or discharge of the Agreement (including these Terms) is effective unless it is in writing, identified as an amendment to or rescission, termination or discharge of the Agreement (including these Terms) and signed by an authorized representative of each Party. No waiver by any Party of any of the provisions of the Agreement (including these Terms) shall be effective unless explicitly set forth in writing and signed by the Party so waiving. Except as otherwise set forth in the Agreement (including these Terms), no failure to exercise, or delay in exercising, any rights, remedy, power or privilege arising from the Agreement (including these Terms) shall operate or be construed as a waiver thereof; nor shall any single or partial exercise of any right, remedy, power or privilege under the Agreement (including these Terms) preclude any other or further exercise thereof or the exercise of any other right, remedy, power or privilege.

15.10. Severability. If any provision of the Agreement (including these Terms) is invalid, illegal or unenforceable in any jurisdiction, such invalidity, illegality or unenforceability shall not affect any other term or provision of the Agreement (including these Terms) or invalidate or render unenforceable such term or provision in any other jurisdiction. On such determination that any term or other provision is invalid, illegal or unenforceable, the Parties shall negotiate in good faith to modify the Agreement so as to effect the original intent of the Parties as closely as possible in a mutually acceptable manner in order that the transactions contemplated by the Agreement (including these Terms) be consummated as originally contemplated to the greatest extent possible.

15.11. Governing Law. The Agreement (including these Terms) is governed by and construed in accordance with the internal laws of the State of Illinois without giving effect to any choice or conflict

EXHIBIT A
GENERAL TERMS AND CONDITIONS
(9-1-1 SERVICES AND SOFTWARE LICENSE)

of law provision or rule that would require or permit the application of the laws of any jurisdiction other than those of the State of Illinois. Service of process, summons, notice or other document by mail to such Party's address set forth in Section 2 of the Agreement will be effective service of process for any suit, action or other proceeding brought in any such court.

15.12. Waiver of Jury Trial. Each Party irrevocably and unconditionally waives any right it may have to a trial by jury in respect of any legal action arising out of or relating to the Agreement or the transactions contemplated by the Agreement (including these Terms).

15.13. Equitable Remedies. Customer acknowledges and agrees that a breach or threatened breach by Customer of any of its obligations under Section 3 of these Terms (Use Restrictions), Section 5 of these Terms (Confidentiality), Section 8 of these Terms (Intellectual Property Rights) or Section 11 of these Terms (Indemnification) would cause INdigital irreparable harm for which monetary damages would not be an adequate remedy and that, in the event of such breach or threatened breach, INdigital will be entitled to equitable relief, including in a restraining order, an injunction, specific performance and any other relief that may be available from any court of competent jurisdiction, without any requirement to post a bond or other security, or to prove actual damages or that monetary damages are not an adequate remedy. Such remedies are not exclusive and are in addition to all other remedies that may be available at law, in equity or otherwise.

15.14. Attorneys' Fees. In the event that any action, suit, or other legal or administrative proceeding is instituted or commenced by either Party against the other Party arising out of or related to the Agreement (including these Terms), the prevailing Party shall be entitled to recover its reasonable attorneys, expert witness and accountants' fees and court costs from the non-prevailing Party.

EXHIBIT B
Designated Sites

Rock Island County Sheriff's Office - RICO
1317 2nd Ave
Rock Island, IL 61201

Rock Island P.D. - RICOMM
1212 Fifth Ave
Rock Island, IL 61201

QCOMM
405 1st St E,
Milan, IL 61264

Rock Island Arsenal
2932 Rodman Avenue
Bldg. 225
Rock Island, IL 61299

EXHIBIT C

Software / Services Description

1. Database Services –

Location Database services for the PSAP. Repository for ALI. Legacy wireline records in the (Rock County, IL) service area will be processed by INdigital using industry standard record exchange and correction methods. i2 format ALI service (wireless, VoIP - using pANi) will be provided by INdigital,

2. Routing Services –

INdigital will design and deploy an NGCS configuration that conforms to standards and includes the necessary components to provide NG9-1-1 using industry standard Functional Elements. Redundant, diverse service aggregation points of presence will be established, and the proposed solution will conform to the current standards and accommodate future adjustments to the standards as they become available.

3. Network Services –

The proposal's objective is to establish a ESiNet (Emergency Services iP Network) to serve existing and new customers in Illinois. This connectivity will be provided by diverse carriers when available. This service enables connectivity to the PSAP for delivery of voice and data for NG9-1-1.

EXHIBIT D
Payments and Fees

Schedule of fees itemized by the features being delivered

Database - [REDACTED]

Routing Services - [REDACTED]

Legacy gateway ports - [REDACTED]

Monthly Recurring Cost - [REDACTED] (elements with * to be billed directly to the Illinois State Police 9-1-1 Administrative Support Command for INdigital NGCS of Database/Selective Routing/Legacy Gateway Ports).

Based on 2018 U.S. Census population data (adjustable based on annual U.S. census data availability).

[REDACTED]

[REDACTED]

Terms of this agreement will be adjusted to adhere to any requirements of the PSAP and/or it's vendor by the State as a result of the Illinois State-wide ESInet project contract.

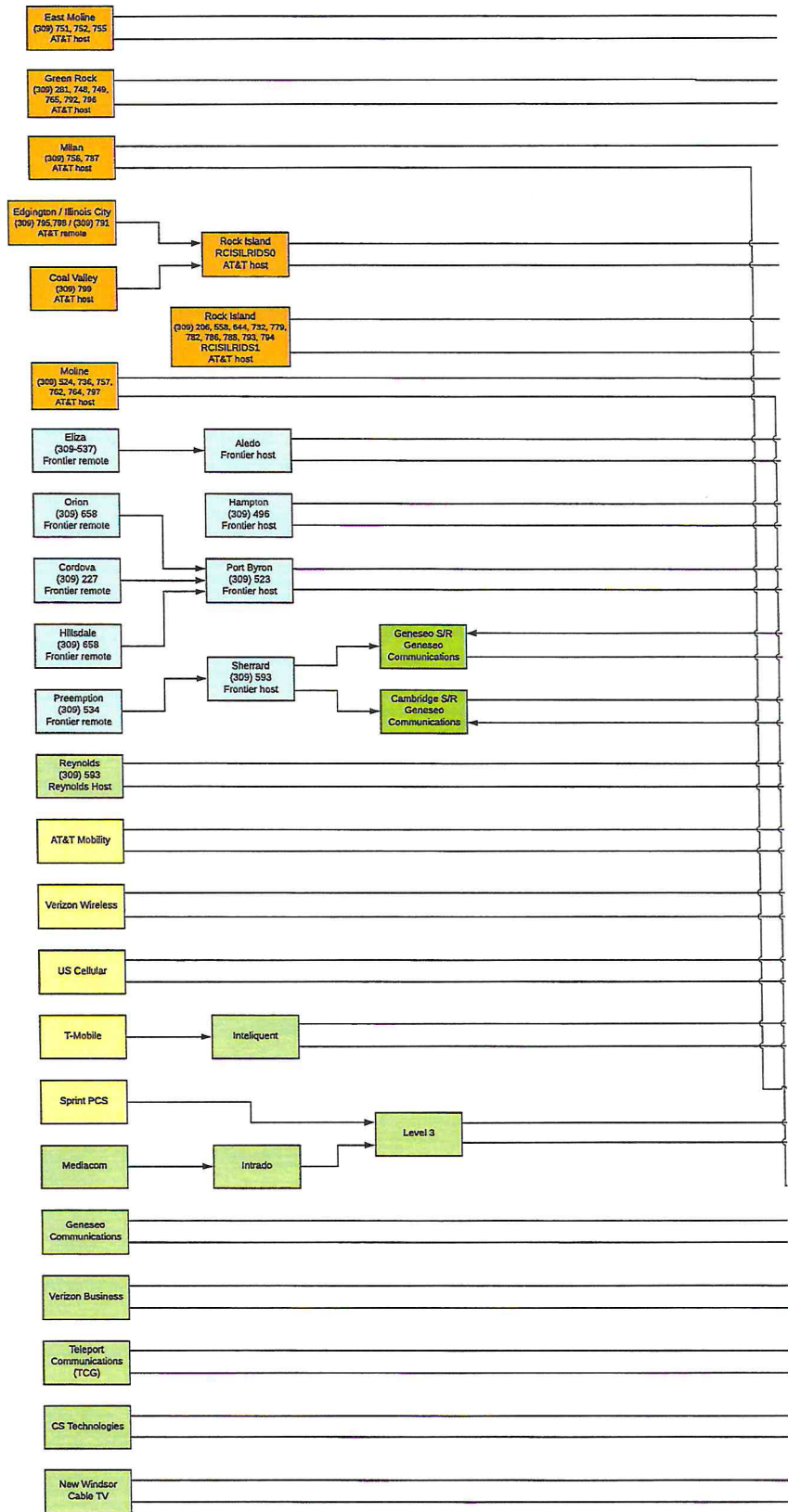

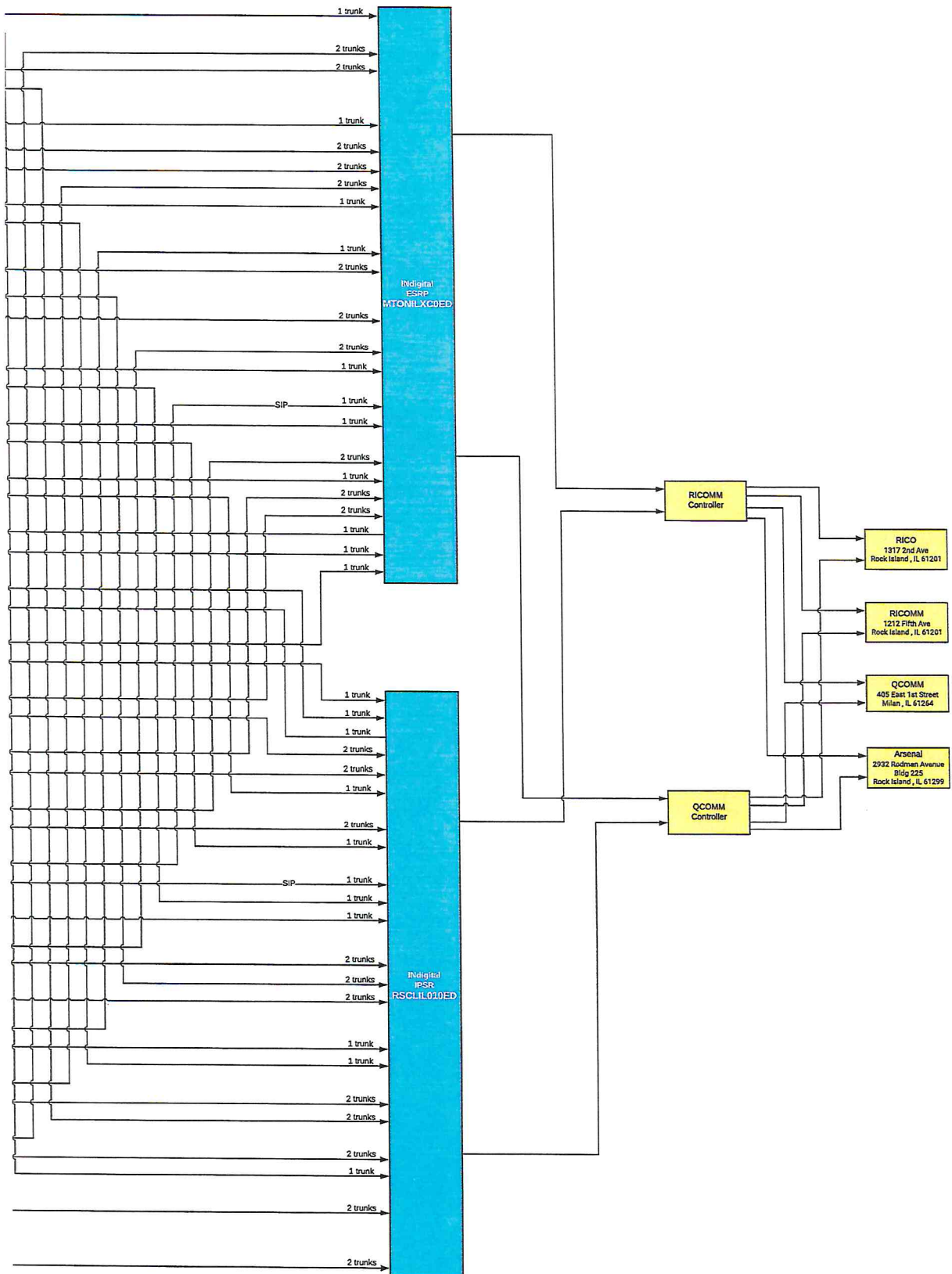

EXHIBITS 8 & 9

January 3, 2017

For Enhanced 9-1-1 Emergency Communications

This agreement is made between the Rock Island County Safety Answering Point, hereinafter referred to as "PSAP", and Illinois State Police, for the purpose of effective call handling and routing of 9-1-1 Emergency calls on a county-wide Enhanced 9-1-1 system.

CALL HANDLING

Rock Island County PSAP, receiving a call for emergency services in your jurisdiction, shall dispatch the call in the following manner:

Primary: (309) 752-4911

Secondary: (309) 752-4912

AID OUTSIDE JURISDICTION BOUNDARY

Once an emergency unit is dispatched in response to a request through the system, such unit shall render its service to the requesting party without regard to whether the unit is operating outside its normal jurisdiction boundaries.

The legislative intent is that 9-1-1 be used for emergency calls only. Therefore, all calls of an administrative or non-emergency nature shall be referred to your agency's published telephone number.

The PSAP agrees to keep all records, times and places of all calls. All records will be available to all participants of the 9-1-1 service.

It shall be the responsibility of your agency to maintain the report of call and the disposition of each call received.

All agreements, management, records and service will be the responsibility of the advisory and policy board.

Any agreements or changes in agreements and operating policies must be approved by the advisory board.

Rock Island County PSAP
By: 
Lt. Darren Hart
Title: PSAP Manager

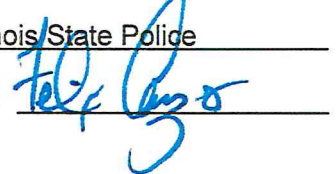
Illinois State Police
By: 
Title: Bureau Chief

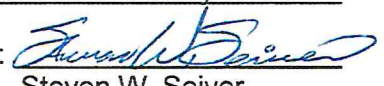
Rock Island County ETSB
By: 
Steven W. Seiver
Title: Chairman

EXHIBITS 8 & 9

December 19, 2013

For Enhanced 9-1-1 Emergency Communications

This agreement is made between the Rock Island County Public Safety Answering Point, hereinafter referred to as "PSAP", and Rock Island County Sheriff's Office, for the purpose of effective call handling and routing of 9-1-1 Emergency calls on a county-wide Enhanced 9-1-1 system.

CALL HANDLING

RI County PSAP, receiving a call for emergency services in your jurisdiction, shall dispatch the call in the following manner:

Primary: WPMP978

Secondary: (309) 794-9111

AID OUTSIDE JURISDICTION BOUNDARY

Once an emergency unit is dispatched in response to a request through the system, such unit shall render its service to the requesting party without regard to whether the unit is operating outside its normal jurisdiction boundaries.

The legislative intent is that 9-1-1 be used for emergency calls only. Therefore, all calls of an administrative or non-emergency nature shall be referred to your agency's published telephone number.

The PSAP agrees to keep all records, times and places of all calls. All records will be available to all participants of the 9-1-1 service.

It shall be the responsibility of your agency to maintain the report of call and the disposition of each call received.

All agreements, management, records and service will be the responsibility of the advisory and policy board.

Any agreements or changes in agreements and operating policies must be approved by the advisory board.

R I County PSAP

By: *Darren Hart*
Darren Hart

Title: Lieutenant

Rock Island County Sheriff

By: *Jeff Boyd*
Jeff Boyd

Title: Sheriff

Rock Island County ETSB

By: *Steven W. Seiver*
Steven W. Seiver

Title: Chairman

EXHIBITS 8 & 9

July 19, 1989

For Enhanced 9-1-1 Emergency Communications

This agreement is made between the Rock Island County Public Safety Answering Point, hereinafter referred to as "PSAP", and the Henry County Sheriff's Department, for the purpose of effective handling and routing of 9-1-1 Emergency calls on a countywide Enhanced 9-1-1 system proposed to be operational January 31, 1990.

CALL HANDLING

Rock Island County PSAP Center receiving a call for emergency services in your jurisdiction shall dispatch the call in the following manner:

Primary: Telephone - (309) 937-3911

Secondary: Radio - 155.055

AID OUTSIDE JURISDICTION BOUNDARY

Once an emergency unit is dispatched in response to a request through the system, such unit shall render its service to the requesting party without regard to whether the unit is operating outside its normal jurisdiction boundaries.

The legislative intent is that 9-1-1 be used for emergency calls only. Therefore, all calls of an administrative or non-emergency nature shall be referred to your agency's published telephone number.

The PSAP Center agrees to keep all records, times, and places of all calls. All records will be available to all participants of the 9-1-1 service.

It shall be the responsibility of your agency to maintain the report of call and the disposition of each call received.

All agreements, management, records, and service will be the responsibility of the advisory and policy board.

Any agreements or changes in agreements and operating policies must be approved by the advisory board.

<u>Rock Island County</u> PSAP	<u>Henry County Sheriff's Department</u> AGENCY	<u>E.T.S.B</u>
BY <u>Michael T. Green</u>	BY <u>[Signature]</u>	BY <u>[Signature]</u>
TITLE <u>Sheriff</u>	TITLE <u>Sheriff</u>	TITLE <u>Chairman</u>

EXHIBITS 8 & 9

July 19, 1989

For Enhanced 9-1-1 Emergency Communications

This agreement is made between the Rock Island County Public Safety Answering Point, hereinafter referred to as "PSAP", and the Whiteside County Sheriff's Department, for the purpose of effective handling and routing of 9-1-1 Emergency calls on a countywide Enhanced 9-1-1 system proposed to be operational January 31, 1990.

CALL HANDLING

Rock Island County PSAP Center receiving a call for emergency services in your jurisdiction shall dispatch the call in the following manner:

Primary: Telephone - (815) 772-4044

Secondary: Radio - 155.370

AID OUTSIDE JURISDICTION BOUNDARY

Once an emergency unit is dispatched in response to a request through the system, such unit shall render its service to the requesting party without regard to whether the unit is operating outside its normal jurisdiction boundaries.

The legislative intent is that 9-1-1 be used for emergency calls only. Therefore, all calls of an administrative or non-emergency nature shall be referred to your agency's published telephone number.

The PSAP Center agrees to keep all records, times, and places of all calls. All records will be available to all participants of the 9-1-1 service.

It shall be the responsibility of your agency to maintain the report of call and the disposition of each call received.

All agreements, management, records, and service will be the responsibility of the advisory and policy board.

Any agreements or changes in agreements and operating policies must be approved by the advisory board.

<u>Rock Island County</u>	<u>Whiteside County Sheriff's</u>	
<u>PSAP</u>	<u>Department</u>	<u>E.T.S.B.</u>
	<u>AGENCY</u>	

BY <u>Michael T. Green</u>	BY <u>W. Kimmel</u>	BY <u>Steven W. Fived</u>
----------------------------	---------------------	---------------------------

TITLE <u>Sheriff</u>	TITLE <u>SHERIFF</u>	TITLE <u>Chairman</u>
----------------------	----------------------	-----------------------

July 19, 1989

For Enhanced 9-1-1 Emergency Communications

This agreement is made between the Rock Island County Public Safety Answering Point, hereinafter referred to as "PSAP", and the Mercer County Sheriff's Department, for the purpose of effective handling and routing of 9-1-1 Emergency calls on a countywide Enhanced 9-1-1 system proposed to be operational January 31, 1990.

CALL HANDLING

Rock Island County PSAP Center receiving a call for emergency services in your jurisdiction shall dispatch the call in the following manner:

Primary: Telephone - (309) 582-5194

Secondary: Administrative Message via LEADS

AID OUTSIDE JURISDICTION BOUNDARY

Once an emergency unit is dispatched in response to a request through the system, such unit shall render its service to the requesting party without regard to whether the unit is operating outside its normal jurisdiction boundaries.

The legislative intent is that 9-1-1 be used for emergency calls only. Therefore, all calls of an administrative or non-emergency nature shall be referred to your agency's published telephone number.

The PSAP Center agrees to keep all records, times, and places of all calls. All records will be available to all participants of the 9-1-1 service.

It shall be the responsibility of your agency to maintain the report of call and the disposition of each call received.

All agreements, management, records, and service will be the responsibility of the advisory and policy board.

Any agreements or changes in agreements and operating policies must be approved by the advisory board.

<u>Rock Island County</u>	<u>Mercer County Sheriff's</u>	
<u>PSAP</u>	<u>Department</u>	<u>E.T.S.B</u>
	<u>AGENCY</u>	
BY <u>Michael T. Green</u>	BY <u>Marvin Hurtgen</u>	BY <u>Steven W. Eiver</u>
TITLE <u>Sheriff</u>	TITLE <u>Sheriff</u>	TITLE <u>Chairman</u>

EXHIBITS 8 & 9

January 8, 2019

For Enhanced 9-1-1 Emergency Communications

This agreement is made between the Rock Island County Public Safety Answering Point, hereinafter referred to as "PSAP", and Milan Police Department, for the purpose of effective call handling and routing of 9-1-1 Emergency calls on a county-wide Enhanced 9-1-1 system.

CALL HANDLING

Rock Island County PSAP, receiving a call for emergency services in your jurisdiction, shall dispatch the call in the following manner:

Primary: 800 MHz (15 channels)

Secondary: (309) 787-8520

AID OUTSIDE JURISDICTION BOUNDARY

Once an emergency unit is dispatched in response to a request through the system, such unit shall render its service to the requesting party without regard to whether the unit is operating outside its normal jurisdiction boundaries.

The legislative intent is that 9-1-1 be used for emergency calls only. Therefore, all calls of an administrative or non-emergency nature shall be referred to your agency's published telephone number.

The PSAP agrees to keep all records, times and places of all calls. All records will be available to all participants of the 9-1-1 service.

It shall be the responsibility of your agency to maintain the report of call and the disposition of each call received.

All agreements, management, records and service will be the responsibility of the advisory and policy board.

Any agreements or changes in agreements and operating policies must be approved by the advisory board.

Rock Island County PSAP

By: _____
Darren Hart

Title: PSAP Director

Milan Police Department

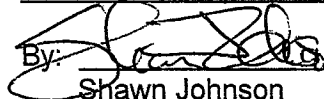
By: 
Shawn Johnson

Title: Chief

Rock Island County ETSB

By: 
Steven W. Seiver

Title: Chairman

EXHIBITS 8 & 9

January 8, 2019

For Enhanced 9-1-1 Emergency Communications

This agreement is made between the Rock Island County Public Safety Answering Point, hereinafter referred to as "PSAP", and City of Moline, for the purpose of effective call handling and routing of 9-1-1 Emergency calls on a county-wide Enhanced 9-1-1 system.

CALL HANDLING

Rock Island County PSAP, receiving a call for emergency services in your jurisdiction, shall dispatch the call in the following manner:

Primary: One Button Transfer to QComm911

Secondary: (309) 797-0401

AID OUTSIDE JURISDICTION BOUNDARY

Once an emergency unit is dispatched in response to a request through the system, such unit shall render its service to the requesting party without regard to whether the unit is operating outside its normal jurisdiction boundaries.

The legislative intent is that 9-1-1 be used for emergency calls only. Therefore, all calls of an administrative or non-emergency nature shall be referred to your agency's published telephone number.

The PSAP agrees to keep all records, times and places of all calls. All records will be available to all participants of the 9-1-1 service.

It shall be the responsibility of your agency to maintain the report of call and the disposition of each call received.

All agreements, management, records and service will be the responsibility of the advisory and policy board.

Any agreements or changes in agreements and operating policies must be approved by the advisory board.

Rock Island County PSAP

By: 
Darren Hart

Title: PSAP Director

City of Moline

By: 
R.T. Finney

Title: Chief

Rock Island County ETSB

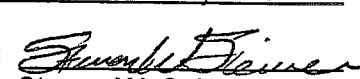
By: 
Steven W. Seiver

Title: Chairman

**PARTICIPATING AGENCY CALL HANDLING &
AID OUTSIDE JURISDICTIONAL BOUNDARIES
AGREEMENT**

9-1-1 EMERGENCY CALL HANDLING DISPATCH PROCEDURES:

This agreement is made between the Rock Island County PSAP ("9-1-1 Authority")
and City of Rock Island (Participating "Public Safety Agency") for the
purpose of effective handling and routing of 9-1-1 Emergency calls.

CALL HANDLING Rock Island County PSAP ("9-1-1 Authority") receiving a call for emergency services in
your jurisdiction shall dispatch the call in the following manner:

Primary: One Button Transfer - Rock Island PSAP (state specific procedures - if radio frequency-
identity frequency number, if talk group-identify name, if telephone-identity telephone number)

Secondary: Radio - 155.370 (state specific procedures - if radio frequency-
identity frequency etc.)

AID OUTSIDE JURISDICTION BOUNDARIES:

Once an emergency unit is dispatched in response to a request through the system, such unit shall
render its service to the requesting party without regard to whether the unit is operating outside its
normal jurisdictional boundaries.

The legislative intent is that 9-1-1 is used for emergency calls only. Therefore, all calls of an
administrative or nonemergency nature shall be referred to your agency's published telephone number.

The PSAP agrees to keep all records, times, and the location of all calls. All records will be available to all
participants of the 9-1-1 System.

It shall be the responsibility of your agency to maintain the report of the call and the disposition of each
call received. All agreements, management, records, and service will be the responsibility of the 9-1-1
Authority.

Rock Island County PSAP

City of Rock Island

9-1-1 Authority Name

Public Safety Agency Name

Signature

Signature

Darren Hart, Captain
Title

Jeff VanHuizen, Chief
Title

11/17/2020
Date

11/17/2020
Date

EXHIBITS 8 & 9

March 6, 1992

For Enhanced 9-1-1 Emergency Communications

This agreement is made between the Rock Island County Public Safety Answering Point, hereinafter referred to as "PSAP", and the Andalusia/Edgington Fire Protection District, for the purpose of effective handling and routing of 9-1-1 Emergency calls on a countywide Enhanced 9-1-1 system.

CALL HANDLING

Rock Island County PSAP Center receiving a call for emergency services in your jurisdiction shall dispatch the call in the following manner:

Primary: Radio - 154.980

Secondary: Telephone - (309) 795-1111 or (309) 798-2030

AID OUTSIDE JURISDICTION BOUNDARY

Once an emergency unit is dispatched in response to a request through the system, such unit shall render its service to the requesting party without regard to whether the unit is operating outside its normal jurisdiction boundaries.

The legislative intent is that 9-1-1 be used for emergency calls only. Therefore, all calls of an administrative or non-emergency nature shall be referred to your agency's published telephone number.

The PSAP Center agrees to keep all records, times, and places of all calls. All records will be available to all participants of the 9-1-1 service.

It shall be the responsibility of your agency to maintain the report of call and the disposition of each call received.

All agreements, management, records, and service will be the responsibility of the advisory and policy board.

Any agreements or changes in agreements and operating policies must be approved by the advisory board.

<u>Rock Island County</u>	<u>Andalusia/Edgington Fire</u>	<u>E.T.S.B</u>
<u>PSAP</u>	<u>Protection District</u>	
	<u>AGENCY</u>	

BY <u>Mike Meehan</u>	BY <u>Richard Lauer</u>	BY <u>Steven W. Seiver</u>
-----------------------	-------------------------	----------------------------

TITLE <u>Sheriff</u>	TITLE <u>Fire Chief</u>	TITLE <u>Chairman</u>
----------------------	-------------------------	-----------------------

SAD/lam
3/6/92
22-2

**PARTICIPATING AGENCY CALL HANDLING &
AID OUTSIDE JURISDICTIONAL BOUNDARIES
AGREEMENT**

9-1-1 EMERGENCY CALL HANDLING DISPATCH PROCEDURES:

This agreement is made between the Rock Island County PSAP ("9-1-1 Authority")
and Andalusia Ambulance (Participating "Public Safety Agency") for the
purpose of effective handling and routing of 9-1-1 Emergency calls.

CALL HANDLING Rock Island County PSAP
("9-1-1 Authority") receiving a call for emergency services in
your jurisdiction shall dispatch the call in the following manner:

Primary: Radio - 154.980 (state specific procedures - if radio frequency-
identity frequency number, if talk group-identify name, if telephone-identity telephone number)

Secondary: Phone - (309) 795-1111 / (309) 798-2030 (state specific procedures - if radio frequency-
identity frequency etc.)

AID OUTSIDE JURISDICTION BOUNDARIES:

Once an emergency unit is dispatched in response to a request through the system, such unit shall
render its service to the requesting party without regard to whether the unit is operating outside its
normal jurisdictional boundaries.

The legislative intent is that 9-1-1 is used for emergency calls only. Therefore, all calls of an
administrative or nonemergency nature shall be referred to your agency's published telephone number.

The PSAP agrees to keep all records, times, and the location of all calls. All records will be available to all
participants of the 9-1-1 System.

It shall be the responsibility of your agency to maintain the report of the call and the disposition of each
call received. All agreements, management, records, and service will be the responsibility of the 9-1-1
Authority.

Rock Island County PSAP

Andalusia Ambulance

9-1-1 Authority Name

Public Safety Agency Name

Signature 

Signature 

Title Darren Hart, Captain

Title President

Date 11/17/2020

Date 11-29-2020

EXHIBITS 8 & 9

January 24, 2019

For Enhanced 9-1-1 Emergency Communications

This agreement is made between the Rock Island County Public Safety Answering Point, hereinafter referred to as "PSAP", and Buffalo Prairie/Illinois City Fire Department, for the purpose of effective call handling and routing of 9-1-1 Emergency calls on a county-wide Enhanced 9-1-1 system.

CALL HANDLING

Rock Island County PSAP, receiving a call for emergency services in your jurisdiction, shall dispatch the call in the following manner:

Primary: 154.980

Secondary: (563) 506-8939, (309) 791-2432

AID OUTSIDE JURISDICTION BOUNDARY

Once an emergency unit is dispatched in response to a request through the system, such unit shall render its service to the requesting party without regard to whether the unit is operating outside its normal jurisdiction boundaries.

The legislative intent is that 9-1-1 be used for emergency calls only. Therefore, all calls of an administrative or non-emergency nature shall be referred to your agency's published telephone number.

The PSAP agrees to keep all records, times and places of all calls. All records will be available to all participants of the 9-1-1 service.

It shall be the responsibility of your agency to maintain the report of call and the disposition of each call received.

All agreements, management, records and service will be the responsibility of the advisory and policy board.

Any agreements or changes in agreements and operating policies must be approved by the advisory board.

Rock Island County PSAP

By: 
Darren Hart

Title: PSAP Director

B Prairie/IL City Fire Department

By: _____
Jason Wolfe

Title: Chief

Rock Island County ETSB

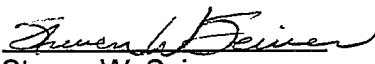
By: 
Steven W. Seiver

Title: Chairman

EXHIBITS 8 & 9

January 8, 2019

For Enhanced 9-1-1 Emergency Communications

This agreement is made between the Rock Island County Public Safety Answering Point, hereinafter referred to as "PSAP", and Carbon Cliff-Barstow Fire District, for the purpose of effective call handling and routing of 9-1-1 Emergency calls on a county-wide Enhanced 9-1-1 system.

CALL HANDLING

Rock Island County PSAP, receiving a call for emergency services in your jurisdiction, shall dispatch the call in the following manner:

Primary: One Button Transfer to QComm911

Secondary: (309) 314-5959

AID OUTSIDE JURISDICTION BOUNDARY

Once an emergency unit is dispatched in response to a request through the system, such unit shall render its service to the requesting party without regard to whether the unit is operating outside its normal jurisdiction boundaries.

The legislative intent is that 9-1-1 be used for emergency calls only. Therefore, all calls of an administrative or non-emergency nature shall be referred to your agency's published telephone number.

The PSAP agrees to keep all records, times and places of all calls. All records will be available to all participants of the 9-1-1 service.

It shall be the responsibility of your agency to maintain the report of call and the disposition of each call received.

All agreements, management, records and service will be the responsibility of the advisory and policy board.

Any agreements or changes in agreements and operating policies must be approved by the advisory board.

Rock Island County PSAP

By: 
Darren Hart

Title: PSAP Director

Carbon Cliff-Barstow Fire

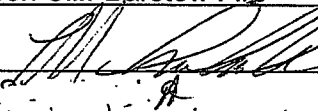
By: 
Matthew Schnepfle

Title: Chief

Rock Island County ETSB

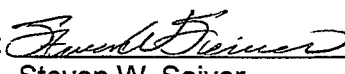
By: 
Steven W. Seiver

Title: Chairman

July 19, 1989

For Enhanced 9-1-1 Emergency Communications

This agreement is made between the Rock Island County Public Safety Answering Point, hereinafter referred to as "PSAP", and the Coal Valley Police Department, for the purpose of effective handling and routing of 9-1-1 Emergency calls on a countywide Enhanced 9-1-1 system proposed to be operational January 31, 1990.

CALL HANDLING

Rock Island County PSAP Center receiving a call for emergency services in your jurisdiction shall dispatch the call in the following manner:

Primary: Radio - 159.150

Secondary: Telephone - (309) 799-5416

AID OUTSIDE JURISDICTION BOUNDARY

Once an emergency unit is dispatched in response to a request through the system, such unit shall render its service to the requesting party without regard to whether the unit is operating outside its normal jurisdiction boundaries.

The legislative intent is that 9-1-1 be used for emergency calls only. Therefore, all calls of an administrative or non-emergency nature shall be referred to your agency's published telephone number.

The PSAP Center agrees to keep all records, times, and places of all calls. All records will be available to all participants of the 9-1-1 service.

It shall be the responsibility of your agency to maintain the report of call and the disposition of each call received.

All agreements, management, records, and service will be the responsibility of the advisory and policy board.

Any agreements or changes in agreements and operating policies must be approved by the advisory board.

<u>Rock Island County</u>	<u>Coal Valley Police Department</u>	<u>E.T.S.B</u>
PSAP	AGENCY	
BY <u>Michael T. Green</u>	BY <u>Patrick R. Fry</u>	BY <u>Steven W. Seiver</u>
TITLE <u>Sheriff</u>	TITLE <u>Village President</u>	TITLE <u>Chairman</u>

**PARTICIPATING AGENCY CALL HANDLING &
AID OUTSIDE JURISDICTIONAL BOUNDARIES
AGREEMENT**

9-1-1 EMERGENCY CALL HANDLING DISPATCH PROCEDURES:

This agreement is made between the Rock Island County PSAP ("9-1-1 Authority")
and Coal Valley Fire/First Responder (Participating "Public Safety Agency") for the
purpose of effective handling and routing of 9-1-1 Emergency calls.

CALL HANDLING Rock Island County PSAP
("9-1-1 Authority") receiving a call for emergency services in
your jurisdiction shall dispatch the call in the following manner:

Primary: Radio - 154.310 (state specific procedures - if radio frequency-
identity frequency number, if talk group-identify name, if telephone-identity telephone number)

Secondary: Phone - (309) 799-5534 (state specific procedures - if radio frequency-
identity frequency etc.)



AID OUTSIDE JURISDICTION BOUNDARIES:

Once an emergency unit is dispatched in response to a request through the system, such unit shall
render its service to the requesting party without regard to whether the unit is operating outside its
normal jurisdictional boundaries.

The legislative intent is that 9-1-1 is used for emergency calls only. Therefore, all calls of an
administrative or nonemergency nature shall be referred to your agency's published telephone number.

The PSAP agrees to keep all records, times, and the location of all calls. All records will be available to all
participants of the 9-1-1 System.

It shall be the responsibility of your agency to maintain the report of the call and the disposition of each
call received. All agreements, management, records, and service will be the responsibility of the 9-1-1
Authority.

<u>Rock Island County PSAP</u>	<u>Coal Valley Fire/First Responder</u>
<u>9-1-1 Authority Name</u>	<u>Public Safety Agency Name</u>
Signature <u></u>	Signature <u></u>
Title <u>Darren Hart, Captain</u>	Title <u>Fire Chief</u>
Date <u>11/17/2020</u>	Date <u>11-18-2020</u>

December 7, 1993

For Enhanced 9-1-1 Emergency Communications

This agreement is made between the Rock Island County Public Safety Answering Point, hereinafter referred to as "PSAP", and the Cordova Volunteer Fire Department, for the purpose of effective handling and routing of 9-1-1 Emergency calls on a countywide Enhanced 9-1-1 system proposed to be operational January 31, 1990.

CALL HANDLING

Rock Island County PSAP Center receiving a call for emergency services in your jurisdiction shall dispatch the call in the following manner:

Primary: Telephone (309) 654-2368 Code 00

Secondary: Radio - 154.190

AID OUTSIDE JURISDICTION BOUNDARY

Once an emergency unit is dispatched in response to a request through the system, such unit shall render its service to the requesting party without regard to whether the unit is operating outside its normal jurisdiction boundaries.

The legislative intent is that 9-1-1 be used for emergency calls only. Therefore, all calls of an administrative or non-emergency nature shall be referred to your agency's published telephone number.

The PSAP Center agrees to keep all records, times, and places of all calls. All records will be available to all participants of the 9-1-1 service.

It shall be the responsibility of your agency to maintain the report of call and the disposition of each call received.

All agreements, management, records, and service will be the responsibility of the advisory and policy board.

Any agreements or changes in agreements and operating policies must be approved by the advisory board.

<u>Rock Island County</u>	<u>Cordova Volunteer Fire</u>	<u>E.T.S.B.</u>
<u>PSAP</u>	<u>Department</u>	
	<u>AGENCY</u>	
BY <u>Richard Gaker</u>	BY <u>Alan McCall</u>	BY <u>Steven W. Sever</u>
TITLE <u>Captain</u>	TITLE <u>Fire Chief</u>	TITLE <u>Chairman</u>

SAD/clc
11-8-93
22-2

**PARTICIPATING AGENCY CALL HANDLING &
AID OUTSIDE JURISDICTIONAL BOUNDARIES
AGREEMENT**

9-1-1 EMERGENCY CALL HANDLING DISPATCH PROCEDURES:

This agreement is made between the Rock Island County PSAP ("9-1-1 Authority")
and Coyne Center Fire/Ambulance (Participating "Public Safety Agency") for the
purpose of effective handling and routing of 9-1-1 Emergency calls.

CALL HANDLING Rock Island County PSAP
("9-1-1 Authority") receiving a call for emergency services in
your jurisdiction shall dispatch the call in the following manner:

Primary: Radio - 154.310 (state specific procedures - if radio frequency-
identity frequency number, if talk group-identify name, if telephone-identity telephone number)

Secondary: Phone - (309) 787-2459 (state specific procedures - if radio frequency-
identity frequency etc.)

AID OUTSIDE JURISDICTION BOUNDARIES:

Once an emergency unit is dispatched in response to a request through the system, such unit shall
render its service to the requesting party without regard to whether the unit is operating outside its
normal jurisdictional boundaries.

The legislative intent is that 9-1-1 is used for emergency calls only. Therefore, all calls of an
administrative or nonemergency nature shall be referred to your agency's published telephone number.

The PSAP agrees to keep all records, times, and the location of all calls. All records will be available to all
participants of the 9-1-1 System.

It shall be the responsibility of your agency to maintain the report of the call and the disposition of each
call received. All agreements, management, records, and service will be the responsibility of the 9-1-1
Authority.

Rock Island County PSAP

Coyne Center Fire/Ambulance

9-1-1 Authority Name

Public Safety Agency Name

Signature *Darren Hart*

Signature *Douglas P. Sumner*

Title Darren Hart, Captain

Title Chief

Date 11/17/2020

Date 11/19/2020

EXHIBITS 8 & 9

January 8, 2019

For Enhanced 9-1-1 Emergency Communications

This agreement is made between the Rock Island County Public Safety Answering Point, hereinafter referred to as "PSAP", and East Moline Fire Department, for the purpose of effective call handling and routing of 9-1-1 Emergency calls on a county-wide Enhanced 9-1-1 system.

CALL HANDLING

Rock Island County PSAP, receiving a call for emergency services in your jurisdiction, shall dispatch the call in the following manner:

Primary: One Button Transfer to QComm911

Secondary: (309) 797-0401

AID OUTSIDE JURISDICTION BOUNDARY

Once an emergency unit is dispatched in response to a request through the system, such unit shall render its service to the requesting party without regard to whether the unit is operating outside its normal jurisdiction boundaries.

The legislative intent is that 9-1-1 be used for emergency calls only. Therefore, all calls of an administrative or non-emergency nature shall be referred to your agency's published telephone number.

The PSAP agrees to keep all records, times and places of all calls. All records will be available to all participants of the 9-1-1 service.

It shall be the responsibility of your agency to maintain the report of call and the disposition of each call received.

All agreements, management, records and service will be the responsibility of the advisory and policy board.

Any agreements or changes in agreements and operating policies must be approved by the advisory board.

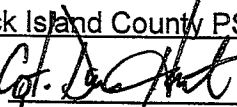
Rock Island County PSAP
By: 
Darren Hart

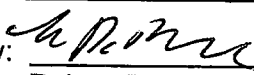
East Moline Fire Department
By: 
Robert DeFrance

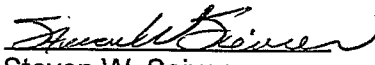
Rock Island County ETSB
By: 
Steven W. Seiver

Title: PSAP Director

Title: Chief

Title: Chairman

EXHIBITS 8 & 9

October 3, 1989

For Enhanced 9-1-1 Emergency Communications

This agreement is made between the Rock Island County Public Safety Answering Point, hereinafter referred to as "PSAP", and the Geneseo Police Department, for the purpose of effective handling and routing of 9-1-1 Emergency calls on a countywide Enhanced 9-1-1 system proposed to be operational January 31, 1990.

CALL HANDLING

Rock Island County PSAP Center receiving a call for emergency services in your jurisdiction shall dispatch the call in the following manner:

Primary: ~~Telephone - 1-944-5141~~

Secondary: Via Henry Co Sheriff on I-Reach: 155.055

AID OUTSIDE JURISDICTION BOUNDARY

Once an emergency unit is dispatched in response to a request through the system, such unit shall render its service to the requesting party without regard to whether the unit is operating outside its normal jurisdiction boundaries.

The legislative intent is that 9-1-1 be used for emergency calls only. Therefore, all calls of an administrative or non-emergency nature shall be referred to your agency's published telephone number.

The PSAP Center agrees to keep all records, times, and places of all calls. All records will be available to all participants of the 9-1-1 service.

It shall be the responsibility of your agency to maintain the report of call and the disposition of each call received.

All agreements, management, records, and service will be the responsibility of the advisory and policy board.

Any agreements or changes in agreements and operating policies must be approved by the advisory board.

<u>Rock Island County</u>	<u>Geneseo Police Department</u>	<u>E.T.S.B.</u>
PSAP	AGENCY	
BY <u>Michael T. Moore</u>	BY <u>Louis Benedick</u>	BY <u>Edward J. Feiner</u>
TITLE <u>SHERIFF</u>	TITLE <u>Chief of Police</u>	TITLE <u>Chairman</u>

SAD/jlh
9-29-89
22-2

**PARTICIPATING AGENCY CALL HANDLING &
AID OUTSIDE JURISDICTIONAL BOUNDARIES
AGREEMENT**

9-1-1 EMERGENCY CALL HANDLING DISPATCH PROCEDURES:

This agreement is made between the Rock Island County PSAP ("9-1-1 Authority")
and Hillsdale Fire Department (Participating "Public Safety Agency") for the
purpose of effective handling and routing of 9-1-1 Emergency calls.

CALL HANDLING Rock Island County PSAP ("9-1-1 Authority") receiving a call for emergency services in
your jurisdiction shall dispatch the call in the following manner:

Primary: Radio - 154.310 (state specific procedures - if radio frequency-
identity frequency number, if talk group-identify name, if telephone-identity telephone number)

Secondary: Phone - (309) 314-1272 (state specific procedures - if radio frequency-
identity frequency etc.)

AID OUTSIDE JURISDICTION BOUNDARIES:

Once an emergency unit is dispatched in response to a request through the system, such unit shall
render its service to the requesting party without regard to whether the unit is operating outside its
normal jurisdictional boundaries.

The legislative intent is that 9-1-1 is used for emergency calls only. Therefore, all calls of an
administrative or nonemergency nature shall be referred to your agency's published telephone number.

The PSAP agrees to keep all records, times, and the location of all calls. All records will be available to all
participants of the 9-1-1 System.

It shall be the responsibility of your agency to maintain the report of the call and the disposition of each
call received. All agreements, management, records, and service will be the responsibility of the 9-1-1
Authority.

Rock Island County PSAP

Hillsdale Fire Department

9-1-1 Authority Name

Public Safety Agency Name

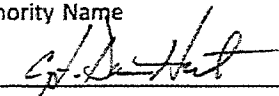
Signature 

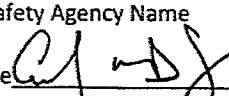
Signature 

Title Darren Hart, Captain

Title ANTHONY M DECAP, CHIEF

Date 11/17/2020

Date 11/24/2020

**PARTICIPATING AGENCY CALL HANDLING &
AID OUTSIDE JURISDICTIONAL BOUNDARIES
AGREEMENT**

9-1-1 EMERGENCY CALL HANDLING DISPATCH PROCEDURES:

This agreement is made between the Rock Island County PSAP ("9-1-1 Authority")
and Orion Fire Department (Participating "Public Safety Agency") for the
purpose of effective handling and routing of 9-1-1 Emergency calls.

CALL HANDLING Rock Island County PSAP
("9-1-1 Authority") receiving a call for emergency services in
your jurisdiction shall dispatch the call in the following manner:

Primary: Phone - (309) 937-3911
(state specific procedures - if radio frequency-
identity frequency number, if talk group-identify name, if telephone-identity telephone number)

Secondary: Phone - (309) 526-3403
(state specific procedures - if radio frequency-
identity frequency etc.)

AID OUTSIDE JURISDICTION BOUNDARIES:

Once an emergency unit is dispatched in response to a request through the system, such unit shall
render its service to the requesting party without regard to whether the unit is operating outside its
normal jurisdictional boundaries.

The legislative intent is that 9-1-1 is used for emergency calls only. Therefore, all calls of an
administrative or nonemergency nature shall be referred to your agency's published telephone number.

The PSAP agrees to keep all records, times, and the location of all calls. All records will be available to all
participants of the 9-1-1 System.

It shall be the responsibility of your agency to maintain the report of the call and the disposition of each
call received. All agreements, management, records, and service will be the responsibility of the 9-1-1
Authority.

Rock Island County PSAP

Orion Fire Department

9-1-1 Authority Name

Public Safety Agency Name

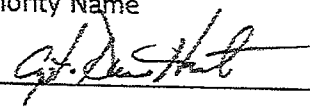
Signature 

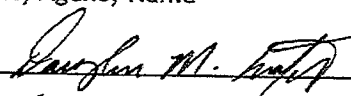
Signature 

Title Darren Hart, Captain

Title Fire Chief

Date 11/17/2020

Date 11-19-2020

**PARTICIPATING AGENCY CALL HANDLING &
AID OUTSIDE JURISDICTIONAL BOUNDARIES
AGREEMENT**

9-1-1 EMERGENCY CALL HANDLING DISPATCH PROCEDURES:

This agreement is made between the Rock Island County PSAP ("9-1-1 Authority")
and Port Byron/Rapids City Fire Department (Participating "Public Safety Agency") for the
purpose of effective handling and routing of 9-1-1 Emergency calls.

CALL HANDLING Rock Island County PSAP ("9-1-1 Authority") receiving a call for emergency services in
your jurisdiction shall dispatch the call in the following manner:

Primary: Radio - 154.310 (state specific procedures - if radio frequency-
identity frequency number, if talk group-identify name, if telephone-identity telephone number)

Secondary: Phone - Various Cell Phones (state specific procedures - if radio frequency-
identity frequency etc.)

AID OUTSIDE JURISDICTION BOUNDARIES:

Once an emergency unit is dispatched in response to a request through the system, such unit shall
render its service to the requesting party without regard to whether the unit is operating outside its
normal jurisdictional boundaries.

The legislative intent is that 9-1-1 is used for emergency calls only. Therefore, all calls of an
administrative or nonemergency nature shall be referred to your agency's published telephone number.

The PSAP agrees to keep all records, times, and the location of all calls. All records will be available to all
participants of the 9-1-1 System.

It shall be the responsibility of your agency to maintain the report of the call and the disposition of each
call received. All agreements, management, records, and service will be the responsibility of the 9-1-1
Authority.

Rock Island County PSAP

Port Byron/Rapids City Fire Department

9-1-1 Authority Name

Public Safety Agency Name

Signature 

Signature 

Title Darren Hart, Captain

Title Chief

Date 11/17/2020

Date 11-18-20

EXHIBITS 8 & 9

January 24, 2019

For Enhanced 9-1-1 Emergency Communications

This agreement is made between the Rock Island County Public Safety Answering Point, hereinafter referred to as "PSAP", and Reynolds Fire Department, for the purpose of effective call handling and routing of 9-1-1 Emergency calls on a county-wide Enhanced 9-1-1 system.

CALL HANDLING

Rock Island County PSAP, receiving a call for emergency services in your jurisdiction, shall dispatch the call in the following manner:

Primary: 150.790

Secondary: (309) 314-6300, (309) 372-8226, (309) 314-5580, (309) 372-4238, (309) 314-4701,
(309) 781-8683

AID OUTSIDE JURISDICTION BOUNDARY

Once an emergency unit is dispatched in response to a request through the system, such unit shall render its service to the requesting party without regard to whether the unit is operating outside its normal jurisdiction boundaries.

The legislative intent is that 9-1-1 be used for emergency calls only. Therefore, all calls of an administrative or non-emergency nature shall be referred to your agency's published telephone number.

The PSAP agrees to keep all records, times and places of all calls. All records will be available to all participants of the 9-1-1 service.

It shall be the responsibility of your agency to maintain the report of call and the disposition of each call received.

All agreements, management, records and service will be the responsibility of the advisory and policy board.

Any agreements or changes in agreements and operating policies must be approved by the advisory board.

Rock Island County PSAP

By: 
Darren Hart

Title: PSAP Director

Reynolds Fire Department

By: 
Marty Gray

Title: Chief

Rock Island County ETSB

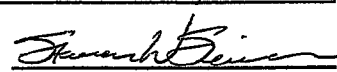
By: 
Steven W. Seiver

Title: Chairman

**PARTICIPATING AGENCY CALL HANDLING &
AID OUTSIDE JURISDICTIONAL BOUNDARIES
AGREEMENT**

9-1-1 EMERGENCY CALL HANDLING DISPATCH PROCEDURES:

This agreement is made between the Rock Island County PSAP ("9-1-1 Authority")
and Rock Island Arsenal PSAP (Participating "Public Safety Agency") for the
purpose of effective handling and routing of 9-1-1 Emergency calls.

CALL HANDLING Rock Island County PSAP ("9-1-1 Authority") receiving a call for emergency services in
your jurisdiction shall dispatch the call in the following manner:

Primary: One Button Transfer to Arsenal PSAP (state specific procedures - if radio frequency-
identity frequency number, if talk group-identify name, if telephone-identity telephone number)

Secondary: Phone - (309) 782-6116 (state specific procedures - if radio frequency-
identity frequency etc.)

AID OUTSIDE JURISDICTION BOUNDARIES:

Once an emergency unit is dispatched in response to a request through the system, such unit shall
render its service to the requesting party without regard to whether the unit is operating outside its
normal jurisdictional boundaries.

The legislative intent is that 9-1-1 is used for emergency calls only. Therefore, all calls of an
administrative or nonemergency nature shall be referred to your agency's published telephone number.

The PSAP agrees to keep all records, times, and the location of all calls. All records will be available to all
participants of the 9-1-1 System.

It shall be the responsibility of your agency to maintain the report of the call and the disposition of each
call received. All agreements, management, records, and service will be the responsibility of the 9-1-1
Authority.

Rock Island County PSAP

Rock Island Arsenal PSAP

9-1-1 Authority Name

Public Safety Agency Name

Signature 

Signature 

Title Darren Hart, Captain

Title Debra Smull, Dispatch Supervisor

Date 11/17/2020

Date 11/19/2020

**PARTICIPATING AGENCY CALL HANDLING &
AID OUTSIDE JURISDICTIONAL BOUNDARIES
AGREEMENT**

9-1-1 EMERGENCY CALL HANDLING DISPATCH PROCEDURES:

This agreement is made between the Rock Island County PSAP ("9-1-1 Authority")
and Sherrard Fire/Ambulance (Participating "Public Safety Agency") for the
purpose of effective handling and routing of 9-1-1 Emergency calls.

CALL HANDLING Rock Island County PSAP
("9-1-1 Authority") receiving a call for emergency services in
your jurisdiction shall dispatch the call in the following manner:

Primary: Radio - 154.980 (state specific procedures - if radio frequency-
identity frequency number, if talk group-identify name, if telephone-identity telephone number)

Secondary: Phone - (309) 582-5194 (state specific procedures - if radio frequency-
identity frequency etc.)

AID OUTSIDE JURISDICTION BOUNDARIES:

Once an emergency unit is dispatched in response to a request through the system, such unit shall
render its service to the requesting party without regard to whether the unit is operating outside its
normal jurisdictional boundaries.

The legislative intent is that 9-1-1 is used for emergency calls only. Therefore, all calls of an
administrative or nonemergency nature shall be referred to your agency's published telephone number.

The PSAP agrees to keep all records, times, and the location of all calls. All records will be available to all
participants of the 9-1-1 System.

It shall be the responsibility of your agency to maintain the report of the call and the disposition of each
call received. All agreements, management, records, and service will be the responsibility of the 9-1-1
Authority.

Rock Island County PSAP

Sherrard Fire/ Ambulance

9-1-1 Authority Name

Public Safety Agency Name

Signature *Darren Hart*

Signature *Gina Blad*

Title Darren Hart, Captain

Title Chief

Date 11/17/2020

Date 12/4/20

EXHIBITS 8 & 9

July 19, 1989

For Enhanced 9-1-1 Emergency Communications

This agreement is made between the Rock Island County Public Safety Answering Point, hereinafter referred to as "PSAP", and the Park Ranger, U.S. Corps of Engineers, for the purpose of effective handling and routing of 9-1-1 Emergency calls on a countywide Enhanced 9-1-1 system proposed to be operational January 31, 1990.

CALL HANDLING

Rock Island County PSAP Center receiving a call for emergency services in your jurisdiction shall dispatch the call in the following manner:

Primary: Radio - 159.150

Secondary: Telephone - N/A

AID OUTSIDE JURISDICTION BOUNDARY

Once an emergency unit is dispatched in response to a request through the system, such unit shall render its service to the requesting party without regard to whether the unit is operating outside its normal jurisdiction boundaries.

The legislative intent is that 9-1-1 be used for emergency calls only. Therefore, all calls of an administrative or non-emergency nature shall be referred to your agency's published telephone number.

The PSAP Center agrees to keep all records, times, and places of all calls. All records will be available to all participants of the 9-1-1 service.

It shall be the responsibility of your agency to maintain the report of call and the disposition of each call received.

All agreements, management, records, and service will be the responsibility of the advisory and policy board.

Any agreements or changes in agreements and operating policies must be approved by the advisory board.

<u>Rock Island County</u>	<u>Park Ranger, U.S. Corps of</u>	<u>E.T.S.B</u>
<u>PSAP</u>	<u>Engineers</u>	
	<u>AGENCY</u>	
BY <u>Michael T. Green</u>	BY <u>[Signature]</u>	BY <u>Steven W. Seiver</u>
TITLE <u>Sheriff</u>	TITLE <u>Supervisory Park Ranger</u>	TITLE <u>Chairman</u>

EXHIBITS 8 & 9

January 8, 2019

For Enhanced 9-1-1 Emergency Communications

This agreement is made between the QComm911 Public Safety Answering Point, hereinafter referred to as "PSAP", and Moline Police Department, for the purpose of effective call handling and routing of 9-1-1 Emergency calls on a county-wide Enhanced 9-1-1 system.

CALL HANDLING

QComm911 PSAP, receiving a call for emergency services in your jurisdiction, shall dispatch the call in the following manner:

Primary: 800 MHz (15 channels)

Secondary: (309) 797-0401

AID OUTSIDE JURISDICTION BOUNDARY

Once an emergency unit is dispatched in response to a request through the system, such unit shall render its service to the requesting party without regard to whether the unit is operating outside its normal jurisdiction boundaries.

The legislative intent is that 9-1-1 be used for emergency calls only. Therefore, all calls of an administrative or non-emergency nature shall be referred to your agency's published telephone number.

The PSAP agrees to keep all records, times and places of all calls. All records will be available to all participants of the 9-1-1 service.

It shall be the responsibility of your agency to maintain the report of call and the disposition of each call received.

All agreements, management, records and service will be the responsibility of the advisory and policy board.

Any agreements or changes in agreements and operating policies must be approved by the advisory board.

QComm911 PSAP

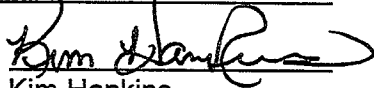
By: 
Kim Hankins

Title: PSAP Director

Moline Police Department

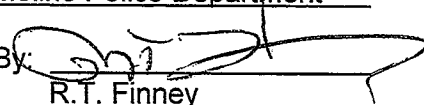
By: 
R.T. Finney

Title: Chief

Rock Island County ETSB

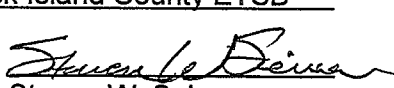
By: 
Steven W. Seiver

Title: Chairman

EXHIBITS 8 & 9

January 8, 2019

For Enhanced 9-1-1 Emergency Communications

This agreement is made between the QComm911 Public Safety Answering Point, hereinafter referred to as "PSAP", and Moline Fire/Ambulance Department, for the purpose of effective call handling and routing of 9-1-1 Emergency calls on a county-wide Enhanced 9-1-1 system.

CALL HANDLING

QComm911 PSAP, receiving a call for emergency services in your jurisdiction, shall dispatch the call in the following manner:

Primary: 800 MHz (15 channels)

Secondary: (309) 797-0401

AID OUTSIDE JURISDICTION BOUNDARY

Once an emergency unit is dispatched in response to a request through the system, such unit shall render its service to the requesting party without regard to whether the unit is operating outside its normal jurisdiction boundaries.

The legislative intent is that 9-1-1 be used for emergency calls only. Therefore, all calls of an administrative or non-emergency nature shall be referred to your agency's published telephone number.

The PSAP agrees to keep all records, times and places of all calls. All records will be available to all participants of the 9-1-1 service.

It shall be the responsibility of your agency to maintain the report of call and the disposition of each call received.

All agreements, management, records and service will be the responsibility of the advisory and policy board.

Any agreements or changes in agreements and operating policies must be approved by the advisory board.

QComm911 PSAP

By: 
Kim Hankins

Title: PSAP Director

Moline Fire Department

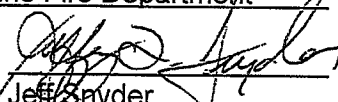
By: 
Jeff Snyder

Title: Chief

Rock Island County ETSB

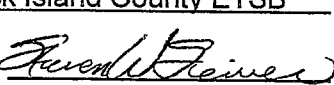
By: 
Steven W. Seiver

Title: Chairman

EXHIBITS 8 & 9

January 8, 2019

For Enhanced 9-1-1 Emergency Communications

This agreement is made between the QComm911 Public Safety Answering Point, hereinafter referred to as "PSAP", and East Moline Police Department, for the purpose of effective call handling and routing of 9-1-1 Emergency calls on a county-wide Enhanced 9-1-1 system.

CALL HANDLING

QComm911 PSAP, receiving a call for emergency services in your jurisdiction, shall dispatch the call in the following manner:

Primary: 800 MHz (15 channels)

Secondary: (309) 752-1555

AID OUTSIDE JURISDICTION BOUNDARY

Once an emergency unit is dispatched in response to a request through the system, such unit shall render its service to the requesting party without regard to whether the unit is operating outside its normal jurisdiction boundaries.

The legislative intent is that 9-1-1 be used for emergency calls only. Therefore, all calls of an administrative or non-emergency nature shall be referred to your agency's published telephone number.

The PSAP agrees to keep all records, times and places of all calls. All records will be available to all participants of the 9-1-1 service.

It shall be the responsibility of your agency to maintain the report of call and the disposition of each call received.

All agreements, management, records and service will be the responsibility of the advisory and policy board.

Any agreements or changes in agreements and operating policies must be approved by the advisory board.

QComm911 PSAP

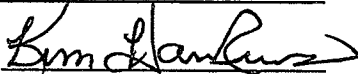
By: 
Kim Hankins

Title: PSAP Director

East Moline Police Department

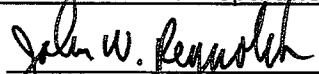
By: 
John Reynolds

Title: Chief

Rock Island County ETSB

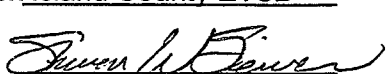
By: 
Steven W. Seiver

Title: Chairman

EXHIBITS 8 & 9

January 8, 2019

For Enhanced 9-1-1 Emergency Communications

This agreement is made between the QComm911 Public Safety Answering Point, hereinafter referred to as "PSAP", and East Moline Fire Department, for the purpose of effective call handling and routing of 9-1-1 Emergency calls on a county-wide Enhanced 9-1-1 system.

CALL HANDLING

QComm911 PSAP, receiving a call for emergency services in your jurisdiction, shall dispatch the call in the following manner:

Primary: 800 MHz (15 channels)

Secondary: (309) 752-1505, (309) 752-1504

AID OUTSIDE JURISDICTION BOUNDARY

Once an emergency unit is dispatched in response to a request through the system, such unit shall render its service to the requesting party without regard to whether the unit is operating outside its normal jurisdiction boundaries.

The legislative intent is that 9-1-1 be used for emergency calls only. Therefore, all calls of an administrative or non-emergency nature shall be referred to your agency's published telephone number.

The PSAP agrees to keep all records, times and places of all calls. All records will be available to all participants of the 9-1-1 service.

It shall be the responsibility of your agency to maintain the report of call and the disposition of each call received.

All agreements, management, records and service will be the responsibility of the advisory and policy board.

Any agreements or changes in agreements and operating policies must be approved by the advisory board.

QComm911 PSAP

By: Kim Hankins
Kim Hankins

Title: PSAP Director

East Moline Fire Department

By: Robert DeFrance
Robert DeFrance

Title: Chief

Rock Island County ETSB

By: Steven W. Seiver
Steven W. Seiver

Title: Chairman

EXHIBITS 8 & 9

January 8, 2019

For Enhanced 9-1-1 Emergency Communications

This agreement is made between the QComm911 Public Safety Answering Point, hereinafter referred to as "PSAP", and Quad City Airport Public Safety, for the purpose of effective call handling and routing of 9-1-1 Emergency calls on a county-wide Enhanced 9-1-1 system.

CALL HANDLING

QComm911 PSAP, receiving a call for emergency services in your jurisdiction, shall dispatch the call in the following manner:

Primary: (309) 757-1513

Secondary: 800 MHz (15 channels)

AID OUTSIDE JURISDICTION BOUNDARY

Once an emergency unit is dispatched in response to a request through the system, such unit shall render its service to the requesting party without regard to whether the unit is operating outside its normal jurisdiction boundaries.

The legislative intent is that 9-1-1 be used for emergency calls only. Therefore, all calls of an administrative or non-emergency nature shall be referred to your agency's published telephone number.

The PSAP agrees to keep all records, times and places of all calls. All records will be available to all participants of the 9-1-1 service.

It shall be the responsibility of your agency to maintain the report of call and the disposition of each call received.

All agreements, management, records and service will be the responsibility of the advisory and policy board.

Any agreements or changes in agreements and operating policies must be approved by the advisory board.

QComm911 PSAP

By: Kim Hankins
Kim Hankins

Title: PSAP Director

Quad City Airport Public Safety

By: Jeff Swan
~~Jeff Patterson~~ - JEFF SWAN

Title: Manager

Rock Island County ETSB

By: Steven W. Seiver
Steven W. Seiver

Title: Chairman

EXHIBITS 8 & 9

January 8, 2019

For Enhanced 9-1-1 Emergency Communications

This agreement is made between the QComm911 Public Safety Answering Point, hereinafter referred to as "PSAP", and Rock Island Police Department, for the purpose of effective call handling and routing of 9-1-1 Emergency calls on a county-wide Enhanced 9-1-1 system.

CALL HANDLING

QComm911 PSAP, receiving a call for emergency services in your jurisdiction, shall dispatch the call in the following manner:

Primary: One Button Transfer to Rock Island PSAP

Secondary: (309) 786-5911

AID OUTSIDE JURISDICTION BOUNDARY

Once an emergency unit is dispatched in response to a request through the system, such unit shall render its service to the requesting party without regard to whether the unit is operating outside its normal jurisdiction boundaries.

The legislative intent is that 9-1-1 be used for emergency calls only. Therefore, all calls of an administrative or non-emergency nature shall be referred to your agency's published telephone number.

The PSAP agrees to keep all records, times and places of all calls. All records will be available to all participants of the 9-1-1 service.

It shall be the responsibility of your agency to maintain the report of call and the disposition of each call received.

All agreements, management, records and service will be the responsibility of the advisory and policy board.

Any agreements or changes in agreements and operating policies must be approved by the advisory board.

QComm911 PSAP

By: 
Kim Hankins

Title: PSAP Director

Rock Island Police Department

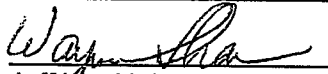
By: 
for Jeff YenHuizen

Title: Chief

Rock Island County ETSB

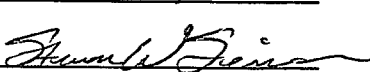
By: 
Steven W. Seiver

Title: Chairman

EXHIBITS 8 & 9

January 8, 2019

For Enhanced 9-1-1 Emergency Communications

This agreement is made between the QComm911 Public Safety Answering Point, hereinafter referred to as "PSAP", and Rock Island Arsenal PSAP, for the purpose of effective call handling and routing of 9-1-1 Emergency calls on a county-wide Enhanced 9-1-1 system.

CALL HANDLING

QComm911 PSAP, receiving a call for emergency services in your jurisdiction, shall dispatch the call in the following manner:

Primary: One Button Transfer to Rock Island Arsenal PSAP

Secondary: (309) 782-6116

AID OUTSIDE JURISDICTION BOUNDARY

Once an emergency unit is dispatched in response to a request through the system, such unit shall render its service to the requesting party without regard to whether the unit is operating outside its normal jurisdiction boundaries.

The legislative intent is that 9-1-1 be used for emergency calls only. Therefore, all calls of an administrative or non-emergency nature shall be referred to your agency's published telephone number.

The PSAP agrees to keep all records, times and places of all calls. All records will be available to all participants of the 9-1-1 service.

It shall be the responsibility of your agency to maintain the report of call and the disposition of each call received.

All agreements, management, records and service will be the responsibility of the advisory and policy board.

Any agreements or changes in agreements and operating policies must be approved by the advisory board.

QComm911 PSAP

Rock Island Arsenal PSAP

Rock Island County ETSB

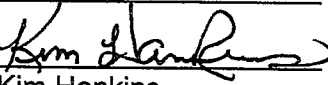
By: 
Kim Hankins

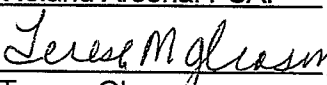
By: 
Terese Gleason

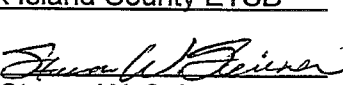
By: 
Steven W. Seiver

Title: PSAP Director

Title: Dispatch Supervisor

Title: Chairman

**PARTICIPATING AGENCY CALL HANDLING &
AID OUTSIDE JURISDICTIONAL BOUNDARIES
AGREEMENT**

9-1-1 EMERGENCY CALL HANDLING DISPATCH PROCEDURES:

This agreement is made between the Rock Island City PSAP ("9-1-1 Authority")
and Rock Island Police Department (Participating "Public Safety Agency") for the
purpose of effective handling and routing of 9-1-1 Emergency calls.

CALL HANDLING Rock Island City PSAP
("9-1-1 Authority") receiving a call for emergency services in
your jurisdiction shall dispatch the call in the following manner:

Primary: Radio - 800 MHz (state specific procedures - if radio frequency-
identity frequency number, if talk group-identify name, if telephone-identity telephone number)

Secondary: Phone - (309) 786-5911 (state specific procedures - if radio frequency-
identity frequency etc.)

AID OUTSIDE JURISDICTION BOUNDARIES:

Once an emergency unit is dispatched in response to a request through the system, such unit shall
render its service to the requesting party without regard to whether the unit is operating outside its
normal jurisdictional boundaries.

The legislative intent is that 9-1-1 is used for emergency calls only. Therefore, all calls of an
administrative or nonemergency nature shall be referred to your agency's published telephone number.

The PSAP agrees to keep all records, times, and the location of all calls. All records will be available to all
participants of the 9-1-1 System.

It shall be the responsibility of your agency to maintain the report of the call and the disposition of each
call received. All agreements, management, records, and service will be the responsibility of the 9-1-1
Authority.

Rock Island City PSAP

Rock Island Police Department

9-1-1 Authority Name

Public Safety Agency Name

Signature James R Morris
Digitally signed by James R Morris
DN: cn=James R Morris, ou=IS of Illinois, ou=MM, MC
Reason: I am approving this document
Location:
Date: 2020.11.17 14:35:06:00

Signature Jeffrey R Ven Huizen
Digitally signed by Jeffrey R Ven Huizen
DN: cn=Jeffrey R Ven Huizen, ou=IS of Illinois, ou=MM
Reason: I am approving this document
Location:
Date: 2020.11.17 14:35:06:00

Title Lt James Morris, Division Commaner

Title Jeff VenHuizen, Chief

Date 11/17/2020

Date 11/17/2020

EXHIBITS 8 & 9

January 5, 2017

For Enhanced 9-1-1 Emergency Communications

This agreement is made between the Rock Island City Public Safety Answering Point, hereinafter referred to as "PSAP", and Rock Island Fire/Ambulance, for the purpose of effective call handling and routing of 9-1-1 Emergency calls on a county-wide Enhanced 9-1-1 system.

CALL HANDLING

Rock Island City PSAP, receiving a call for emergency services in your jurisdiction, shall dispatch the call in the following manner:

Primary: 800 MHz

Secondary: (309) 732-2800

AID OUTSIDE JURISDICTION BOUNDARY

Once an emergency unit is dispatched in response to a request through the system, such unit shall render its service to the requesting party without regard to whether the unit is operating outside its normal jurisdiction boundaries.

The legislative intent is that 9-1-1 be used for emergency calls only. Therefore, all calls of an administrative or non-emergency nature shall be referred to your agency's published telephone number.

The PSAP agrees to keep all records, times and places of all calls. All records will be available to all participants of the 9-1-1 service.

It shall be the responsibility of your agency to maintain the report of call and the disposition of each call received.

All agreements, management, records and service will be the responsibility of the advisory and policy board.

Any agreements or changes in agreements and operating policies must be approved by the advisory board.

Rock Island City PSAP

By: Wayne Sharer
Wayne Sharer

Title: PSAP Manager

Rock Island Fire/Ambulance

By: Jeffrey Yerkey
Jeffrey Yerkey

Title: Chief

Rock Island County ETSB

By: Steven W. Seiver
Steven W. Seiver

Title: Chairman

**PARTICIPATING AGENCY CALL HANDLING &
AID OUTSIDE JURISDICTIONAL BOUNDARIES
AGREEMENT**

9-1-1 EMERGENCY CALL HANDLING DISPATCH PROCEDURES:

This agreement is made between the Rock Island City PSAP ("9-1-1 Authority")
and Rock Island Arsenal PSAP (Participating "Public Safety Agency") for the
purpose of effective handling and routing of 9-1-1 Emergency calls.

CALL HANDLING Rock Island City PSAP ("9-1-1 Authority") receiving a call for emergency services in
your jurisdiction shall dispatch the call in the following manner:

Primary: One Button Transfer to Arsenal PSAP (state specific procedures - if radio frequency-
identity frequency number, if talk group-identify name, if telephone-identity telephone number)

Secondary: Phone - (309) 782-6116 (state specific procedures - if radio frequency-
identity frequency etc.)

AID OUTSIDE JURISDICTION BOUNDARIES:

Once an emergency unit is dispatched in response to a request through the system, such unit shall
render its service to the requesting party without regard to whether the unit is operating outside its
normal jurisdictional boundaries.

The legislative intent is that 9-1-1 is used for emergency calls only. Therefore, all calls of an
administrative or nonemergency nature shall be referred to your agency's published telephone number.

The PSAP agrees to keep all records, times, and the location of all calls. All records will be available to all
participants of the 9-1-1 System.

It shall be the responsibility of your agency to maintain the report of the call and the disposition of each
call received. All agreements, management, records, and service will be the responsibility of the 9-1-1
Authority.

Rock Island City PSAP

Rock Island Arsenal PSAP

9-1-1 Authority Name

Public Safety Agency Name

Signature James R Morris
Digitally signed by James R Morris
DN: cn=James R Morris, o=Rock Island City PSAP
Reason: I agree to the terms defined by the document of my
signature in this document.
Location:
Date: 2020.11.17 14:37:00.00

Signature SMULL.DEBRA.K.1 381223910
Digitally signed by
SMULL.DEBRA.K.1381223910
Date: 2020.11.19 07:02:17 -06'00'

Title Lt James Morris, Division Commander

Title Debra Smull, Dispatch Supervisor

Date 11/17/2020

Date 11/19/2020

EXHIBITS 8 & 9

January 8, 2019

For Enhanced 9-1-1 Emergency Communications

This agreement is made between the QComm911 Public Safety Answering Point, hereinafter referred to as "PSAP", and Silvis Police Department, for the purpose of effective call handling and routing of 9-1-1 Emergency calls on a county-wide Enhanced 9-1-1 system.

CALL HANDLING

QComm911 PSAP, receiving a call for emergency services in your jurisdiction, shall dispatch the call in the following manner:

Primary: 800 MHz (15 channels)

Secondary: (309) 792-1841

AID OUTSIDE JURISDICTION BOUNDARY

Once an emergency unit is dispatched in response to a request through the system, such unit shall render its service to the requesting party without regard to whether the unit is operating outside its normal jurisdiction boundaries.

The legislative intent is that 9-1-1 be used for emergency calls only. Therefore, all calls of an administrative or non-emergency nature shall be referred to your agency's published telephone number.

The PSAP agrees to keep all records, times and places of all calls. All records will be available to all participants of the 9-1-1 service.

It shall be the responsibility of your agency to maintain the report of call and the disposition of each call received.

All agreements, management, records and service will be the responsibility of the advisory and policy board.

Any agreements or changes in agreements and operating policies must be approved by the advisory board.

QComm911 PSAP

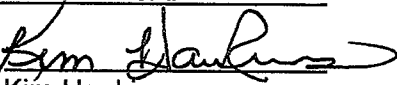
By: 
Kim Hankins

Title: PSAP Director

Silvis Police Department

By: 
Mark VanKlaveren

Title: Chief

Rock Island County ETSB

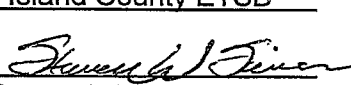
By: 
Steven W. Seiver

Title: Chairman

EXHIBITS 8 & 9

January 8, 2019

For Enhanced 9-1-1 Emergency Communications

This agreement is made between the QComm911 Public Safety Answering Point, hereinafter referred to as "PSAP", and Silvis Fire Department, for the purpose of effective call handling and routing of 9-1-1 Emergency calls on a county-wide Enhanced 9-1-1 system.

CALL HANDLING

QComm911 PSAP, receiving a call for emergency services in your jurisdiction, shall dispatch the call in the following manner:

Primary: 155.895

Secondary: (309) 792-1821

AID OUTSIDE JURISDICTION BOUNDARY

Once an emergency unit is dispatched in response to a request through the system, such unit shall render its service to the requesting party without regard to whether the unit is operating outside its normal jurisdiction boundaries.

The legislative intent is that 9-1-1 be used for emergency calls only. Therefore, all calls of an administrative or non-emergency nature shall be referred to your agency's published telephone number.

The PSAP agrees to keep all records, times and places of all calls. All records will be available to all participants of the 9-1-1 service.

It shall be the responsibility of your agency to maintain the report of call and the disposition of each call received.

All agreements, management, records and service will be the responsibility of the advisory and policy board.

Any agreements or changes in agreements and operating policies must be approved by the advisory board.

QComm911 PSAP

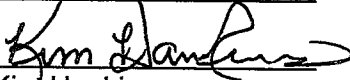
By: 
Kim Hankins

Title: PSAP Director

Silvis Fire Department

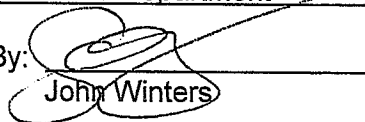
By: 
John Winters

Title: Chief

Rock Island County ET&SB

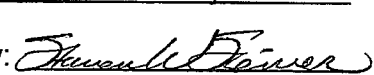
By: 
Steven W. Seiver

Title: Chairman

EXHIBITS 8 & 9

January 8, 2019

For Enhanced 9-1-1 Emergency Communications

This agreement is made between the QComm911 Public Safety Answering Point, hereinafter referred to as "PSAP", and Carbon Cliff-Barstow Fire District, for the purpose of effective call handling and routing of 9-1-1 Emergency calls on a county-wide Enhanced 9-1-1 system.

CALL HANDLING

QComm911 PSAP, receiving a call for emergency services in your jurisdiction, shall dispatch the call in the following manner:

Primary: 155.895

Secondary: (309) 314-5959

AID OUTSIDE JURISDICTION BOUNDARY

Once an emergency unit is dispatched in response to a request through the system, such unit shall render its service to the requesting party without regard to whether the unit is operating outside its normal jurisdiction boundaries.

The legislative intent is that 9-1-1 be used for emergency calls only. Therefore, all calls of an administrative or non-emergency nature shall be referred to your agency's published telephone number.

The PSAP agrees to keep all records, times and places of all calls. All records will be available to all participants of the 9-1-1 service.

It shall be the responsibility of your agency to maintain the report of call and the disposition of each call received.

All agreements, management, records and service will be the responsibility of the advisory and policy board.

Any agreements or changes in agreements and operating policies must be approved by the advisory board.

QComm911 PSAP

By: Kim Hankins
Kim Hankins

Title: PSAP Director

Carbon Cliff-Barstow Fire

By: Matthew Schreyer
Matthew Schreyer

Title: Chief

Rock Island County ETSB

By: Steven W. Seiver
Steven W. Seiver

Title: Chairman

EXHIBITS 8 & 9

January 8, 2019

For Enhanced 9-1-1 Emergency Communications

This agreement is made between the QComm911 Public Safety Answering Point, hereinafter referred to as "PSAP", and Hampton Police Department, for the purpose of effective call handling and routing of 9-1-1 Emergency calls on a county-wide Enhanced 9-1-1 system.

CALL HANDLING

QComm911 PSAP, receiving a call for emergency services in your jurisdiction, shall dispatch the call in the following manner:

Primary: 800 MHz (15 channels)

Secondary: (309) 737-3144

AID OUTSIDE JURISDICTION BOUNDARY

Once an emergency unit is dispatched in response to a request through the system, such unit shall render its service to the requesting party without regard to whether the unit is operating outside its normal jurisdiction boundaries.

The legislative intent is that 9-1-1 be used for emergency calls only. Therefore, all calls of an administrative or non-emergency nature shall be referred to your agency's published telephone number.

The PSAP agrees to keep all records, times and places of all calls. All records will be available to all participants of the 9-1-1 service.

It shall be the responsibility of your agency to maintain the report of call and the disposition of each call received.

All agreements, management, records and service will be the responsibility of the advisory and policy board.

Any agreements or changes in agreements and operating policies must be approved by the advisory board.

QComm911 PSAP

By: Kim Hankins
Kim Hankins

Title: PSAP Director

Hampton Police Department

By: David Perley
David Perley

Title: Chief

Rock Island County ETSB

By: Steven W. Seiver
Steven W. Seiver

Title: Chairman

EXHIBITS 8 & 9

January 8, 2019

For Enhanced 9-1-1 Emergency Communications

This agreement is made between the QComm911 Public Safety Answering Point, hereinafter referred to as "PSAP", and Hampton Fire Department, for the purpose of effective call handling and routing of 9-1-1 Emergency calls on a county-wide Enhanced 9-1-1 system.

CALL HANDLING

QComm911 PSAP, receiving a call for emergency services in your jurisdiction, shall dispatch the call in the following manner:

Primary: 155.895

Secondary: (309) 755-6182

AID OUTSIDE JURISDICTION BOUNDARY

Once an emergency unit is dispatched in response to a request through the system, such unit shall render its service to the requesting party without regard to whether the unit is operating outside its normal jurisdiction boundaries.

The legislative intent is that 9-1-1 be used for emergency calls only. Therefore, all calls of an administrative or non-emergency nature shall be referred to your agency's published telephone number.

The PSAP agrees to keep all records, times and places of all calls. All records will be available to all participants of the 9-1-1 service.

It shall be the responsibility of your agency to maintain the report of call and the disposition of each call received.

All agreements, management, records and service will be the responsibility of the advisory and policy board.

Any agreements or changes in agreements and operating policies must be approved by the advisory board.

QComm911 PSAP

By: Kim Hankins
Kim Hankins

Title: PSAP Director

Hampton Fire Department

By: Dave Johnson
Dave Johnson

Title: Chief

Rock Island County ETSB

By: Steven W. Seiver
Steven W. Seiver

Title: Chairman

EXHIBITS 8 & 9

January 8, 2019

For Enhanced 9-1-1 Emergency Communications

This agreement is made between the QComm911 Public Safety Answering Point, hereinafter referred to as "PSAP", and Milan Police Department, for the purpose of effective call handling and routing of 9-1-1 Emergency calls on a county-wide Enhanced 9-1-1 system.

CALL HANDLING

QComm911 PSAP, receiving a call for emergency services in your jurisdiction, shall dispatch the call in the following manner:

Primary: 800 MHz (15 channels)

Secondary: (309) 787-8520

AID OUTSIDE JURISDICTION BOUNDARY

Once an emergency unit is dispatched in response to a request through the system, such unit shall render its service to the requesting party without regard to whether the unit is operating outside its normal jurisdiction boundaries.

The legislative intent is that 9-1-1 be used for emergency calls only. Therefore, all calls of an administrative or non-emergency nature shall be referred to your agency's published telephone number.

The PSAP agrees to keep all records, times and places of all calls. All records will be available to all participants of the 9-1-1 service.

It shall be the responsibility of your agency to maintain the report of call and the disposition of each call received.

All agreements, management, records and service will be the responsibility of the advisory and policy board.

Any agreements or changes in agreements and operating policies must be approved by the advisory board.

QComm911 PSAP

Milan Police Department

Rock Island County ETSB

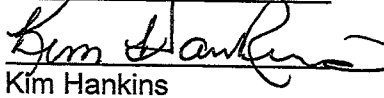
By: 
Kim Hankins

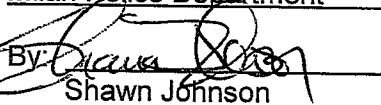
By: 
Shawn Johnson

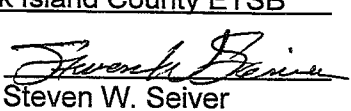
By: 
Steven W. Seiver

Title: PSAP Director

Title: Chief

Title: Chairman

EXHIBITS 8 & 9

January 8, 2019

For Enhanced 9-1-1 Emergency Communications

This agreement is made between the QComm911 Public Safety Answering Point, hereinafter referred to as "PSAP", and Black Hawk Fire Department, for the purpose of effective call handling and routing of 9-1-1 Emergency calls on a county-wide Enhanced 9-1-1 system.

CALL HANDLING

QComm911 PSAP, receiving a call for emergency services in your jurisdiction, shall dispatch the call in the following manner:

Primary: 154.160

Secondary: (309) 787-8520

AID OUTSIDE JURISDICTION BOUNDARY

Once an emergency unit is dispatched in response to a request through the system, such unit shall render its service to the requesting party without regard to whether the unit is operating outside its normal jurisdiction boundaries.

The legislative intent is that 9-1-1 be used for emergency calls only. Therefore, all calls of an administrative or non-emergency nature shall be referred to your agency's published telephone number.

The PSAP agrees to keep all records, times and places of all calls. All records will be available to all participants of the 9-1-1 service.

It shall be the responsibility of your agency to maintain the report of call and the disposition of each call received.

All agreements, management, records and service will be the responsibility of the advisory and policy board.

Any agreements or changes in agreements and operating policies must be approved by the advisory board.

QComm911 PSAP

By: Kim Hankins
Kim Hankins

Title: PSAP Director

Black Hawk Fire Department

By: Doug Dubree
Doug Dubree

Title: Chief

Rock Island County ETSB

By: Steven W. Seiver
Steven W. Seiver

Title: Chairman

**PARTICIPATING AGENCY CALL HANDLING &
AID OUTSIDE JURISDICTIONAL BOUNDARIES
AGREEMENT**

9-1-1 EMERGENCY CALL HANDLING DISPATCH PROCEDURES:

This agreement is made between the Rock Island Arsenal PSAP ("9-1-1 Authority")
and Rock Island City PSAP (Participating "Public Safety Agency") for the
purpose of effective handling and routing of 9-1-1 Emergency calls.

CALL HANDLING Rock Island Arsenal PSAP ("9-1-1 Authority") receiving a call for emergency services in
your jurisdiction shall dispatch the call in the following manner:

Primary: One Button Transfer to R Island PSAP (state specific procedures - if radio frequency-
identity frequency number, if talk group-identify name, if telephone-identity telephone number)

Secondary: Phone - (309) 786-5911 (state specific procedures - if radio frequency-
identity frequency etc.)

AID OUTSIDE JURISDICTION BOUNDARIES:

Once an emergency unit is dispatched in response to a request through the system, such unit shall
render its service to the requesting party without regard to whether the unit is operating outside its
normal jurisdictional boundaries.

The legislative intent is that 9-1-1 is used for emergency calls only. Therefore, all calls of an
administrative or nonemergency nature shall be referred to your agency's published telephone number.

The PSAP agrees to keep all records, times, and the location of all calls. All records will be available to all
participants of the 9-1-1 System.

It shall be the responsibility of your agency to maintain the report of the call and the disposition of each
call received. All agreements, management, records, and service will be the responsibility of the 9-1-1
Authority.

Rock Island Arsenal PSAP

Rock Island City PSAP

9-1-1 Authority Name

Public Safety Agency Name

SMULL,DEBRA.K. Digitally signed by
SMULL,DEBRA.K.1381223910
Signature 1381223910 Date: 2020.11.17 12:17:20 -06'00'

James R Morris
Signature James R Morris
Digitally signed by James R Morris
DN: cn=James R Morris, o=City of Illinois, ou=RIAMAC
Reason: I agree to the terms defined by the placement of my
signature in this document.
Location:
Date: 2020-11-17 16:12:05-05

Title Debra Smull, Dispatch Supervisor

Title James Morris, Division Commander

Date 11/17/2020

Date 11/17/2020

**PARTICIPATING AGENCY CALL HANDLING &
AID OUTSIDE JURISDICTIONAL BOUNDARIES
AGREEMENT**

9-1-1 EMERGENCY CALL HANDLING DISPATCH PROCEDURES:

This agreement is made between the Rock Island County PSAP ("9-1-1 Authority")
and Genesis Ambulance Service (Participating "Public Safety Agency") for the
purpose of effective handling and routing of 9-1-1 Emergency calls.

CALL HANDLING Rock Island County PSAP
("9-1-1 Authority") receiving a call for emergency services in
your jurisdiction shall dispatch the call in the following manner:

Primary: Phone - (563) 322-3995 (state specific procedures - if radio frequency-
identity frequency number, if talk group-identify name, if telephone-identity telephone number)

Secondary: Radio - Fire Mutual Aid Channel 154.31 (state specific procedures - if radio frequency-
identity frequency etc.)

AID OUTSIDE JURISDICTION BOUNDARIES:

Once an emergency unit is dispatched in response to a request through the system, such unit shall
render its service to the requesting party without regard to whether the unit is operating outside its
normal jurisdictional boundaries.

The legislative intent is that 9-1-1 is used for emergency calls only. Therefore, all calls of an
administrative or nonemergency nature shall be referred to your agency's published telephone number.

The PSAP agrees to keep all records, times, and the location of all calls. All records will be available to all
participants of the 9-1-1 System.

It shall be the responsibility of your agency to maintain the report of the call and the disposition of each
call received. All agreements, management, records, and service will be the responsibility of the 9-1-1
Authority.

Rock Island County PSAP

9-1-1 Authority Name

Signature

Title Darren Hart, Captain

Date

12/3/2020

Genesis Ambulance Service

Public Safety Agency Name

Signature

Title Director Genesis's Ambulance

Date

12/4/2020

**PARTICIPATING AGENCY CALL HANDLING &
AID OUTSIDE JURISDICTIONAL BOUNDARIES
AGREEMENT**

9-1-1 EMERGENCY CALL HANDLING DISPATCH PROCEDURES:

This agreement is made between the Rock Island County PSAP ("9-1-1 Authority")
and Advanced Medical Transport (Participating "Public Safety Agency") for the
purpose of effective handling and routing of 9-1-1 Emergency calls.

CALL HANDLING Rock Island County PSAP
("9-1-1 Authority") receiving a call for emergency services in
your jurisdiction shall dispatch the call in the following manner:

Primary: Phone - (309) 434-6200 494-6200 (state specific procedures - if radio frequency-
identity frequency number, if talk group-identify name, if telephone-identity telephone number)

Secondary: Radio - Local Gov Channel 154.98 (state specific procedures - if radio frequency-
identity frequency etc.)

AID OUTSIDE JURISDICTION BOUNDARIES:

Once an emergency unit is dispatched in response to a request through the system, such unit shall
render its service to the requesting party without regard to whether the unit is operating outside its
normal jurisdictional boundaries.

The legislative intent is that 9-1-1 is used for emergency calls only. Therefore, all calls of an
administrative or nonemergency nature shall be referred to your agency's published telephone number.

The PSAP agrees to keep all records, times, and the location of all calls. All records will be available to all
participants of the 9-1-1 System.

It shall be the responsibility of your agency to maintain the report of the call and the disposition of each
call received. All agreements, management, records, and service will be the responsibility of the 9-1-1
Authority.

Rock Island County PSAP

Advanced Medical Transport

9-1-1 Authority Name

Public Safety Agency Name

Signature 

Signature 

Title Darren Hart, Captain

Title VP of Operations

Date 12/3/2020

Date 12/3/2020

**PARTICIPATING AGENCY CALL HANDLING &
AID OUTSIDE JURISDICTIONAL BOUNDARIES
AGREEMENT**

9-1-1 EMERGENCY CALL HANDLING DISPATCH PROCEDURES:

This agreement is made between the QComm911 PSAP ("9-1-1 Authority")
and Genesis Ambulance Services (Participating "Public Safety Agency") for the
purpose of effective handling and routing of 9-1-1 Emergency calls.

CALL HANDLING QComm911 PSAP
("9-1-1 Authority") receiving a call for emergency services in
your jurisdiction shall dispatch the call in the following manner:

Primary: Telephone - (309) 792-8634 (state specific procedures - if radio frequency-
identity frequency number, if talk group-identify name, if telephone-identity telephone number)

Secondary: RACOM-MOEMFDS & SILVIS_FIRE (state specific procedures - if radio frequency-
identity frequency etc.)

AID OUTSIDE JURISDICTION BOUNDARIES:

Once an emergency unit is dispatched in response to a request through the system, such unit shall
render its service to the requesting party without regard to whether the unit is operating outside its
normal jurisdictional boundaries.

The legislative intent is that 9-1-1 is used for emergency calls only. Therefore, all calls of an
administrative or nonemergency nature shall be referred to your agency's published telephone number.

The PSAP agrees to keep all records, times, and the location of all calls. All records will be available to all
participants of the 9-1-1 System.

It shall be the responsibility of your agency to maintain the report of the call and the disposition of each
call received. All agreements, management, records, and service will be the responsibility of the 9-1-1
Authority.

QComm911 PSAP

Genesis Ambulance Services

9-1-1 Authority Name

Public Safety Agency Name

Signature Terry McMaster
D:public signed by Terry McMaster
DN: cn=Terry McMaster, o=QComm911,
ou=ETSA, email=tmcmaster@qcomm911.org,
c=US
Date: 2020.12.07 09:34:25 -0500

Signature 

Title Terry McMaster, Director

Title Adam Haut, Director

Date December 7, 2020

Date December 7, 2020

**PARTICIPATING AGENCY CALL HANDLING &
AID OUTSIDE JURISDICTIONAL BOUNDARIES
AGREEMENT**

9-1-1 EMERGENCY CALL HANDLING DISPATCH PROCEDURES:

This agreement is made between the QComm911 PSAP ("9-1-1 Authority")
and Advanced Medical Transport (Participating "Public Safety Agency") for the
purpose of effective handling and routing of 9-1-1 Emergency calls.

CALL HANDLING QComm911 PSAP
("9-1-1 Authority") receiving a call for emergency services in
your jurisdiction shall dispatch the call in the following manner:

Primary: Telephone - ~~(309) 949-6200~~ 309-494-6200
(state specific procedures - if radio frequency-
identity frequency number, if talk group-identify name, if telephone-identity telephone number)

Secondary: RACOM EDACS - AMT_QCA talk group
(state specific procedures - if radio frequency-
identity frequency etc.)

AID OUTSIDE JURISDICTION BOUNDARIES:

Once an emergency unit is dispatched in response to a request through the system, such unit shall
render its service to the requesting party without regard to whether the unit is operating outside its
normal jurisdictional boundaries.

The legislative intent is that 9-1-1 is used for emergency calls only. Therefore, all calls of an
administrative or nonemergency nature shall be referred to your agency's published telephone number.

The PSAP agrees to keep all records, times, and the location of all calls. All records will be available to all
participants of the 9-1-1 System.

It shall be the responsibility of your agency to maintain the report of the call and the disposition of each
call received. All agreements, management, records, and service will be the responsibility of the 9-1-1
Authority.

QComm911 PSAP

Advanced Medical Transport (AMT)

9-1-1 Authority Name

Public Safety Agency Name

Signature Terry McMaster

Signature Tom Geraci

Title Terry McMaster, Director

Title Tom Geraci, Vice President of Operations

Date November 24, 2020

Date November 25, 2020